

INSTALLATION & USER INSTRUCTIONS

WALL MOUNTED LED ELECTRIC FIRE



SUPERIORFIRES

Superior Fires

Christchurch, Dorset BH23 2BT

Tel: 01202 588 632

Fax: 01202 499326

www.superiorfires.co.uk

Email : sales@superiorfires.co.uk

MODELS COVERED BY THESE INSTRUCTIONS

**EBONY GRAND LED ELECTRIC
EF11-16**



Model Shown: Ebony Grand

Please note : Except where otherwise stated, all rights, including copyright in the text, images and layout of this booklet is owned by Focal Point Fires plc. You are not permitted to copy or adapt any of the content without the prior written permission of Focal Point Fires plc.

All instructions must be handed to the user for safekeeping.

Revision A - 04/16

Section	Contents	Page No.	Section	Contents	Page No.
1.0	Preliminary Notes	2	8.1	Removing the Front Glass	6
2.0	Appliance Data	3	8.2	Installing the Crystal Embers	7
3.0	Electrical Installation Requirements	3	9.0	Operating the Appliance	7
4.0	Component Checklist	3	10.0	Safety cut-out System	7
5.0	Site Requirements	3	11.0	Cleaning and Maintenance	8
6.0	Clearances to Combustible Materials	4	12.0	Servicing	8
7.0	Unpacking the Appliance	4	13.0	Appliance Dimensions	8
8.0	Installation	4	14.0	Guarantee - Terms and Conditions	9

I.0 PRELIMINARY NOTES

IMPORTANT - THESE INSTRUCTIONS SHOULD BE READ CAREFULLY AND RETAINED FOR FUTURE REFERENCE.

When using this electrical appliance, basic precautions should be followed to reduce the risk of fire, electric shock and injury to person, including the following:

- This heater must be used on an AC supply only and the voltage marked on the heater's rating label must correspond to the supply voltage.
- **DO NOT** switch the appliance on until it is properly installed as described in this manual.
- This appliance can be used by children aged from 8 years and above and persons with reduced physical, sensory or mental capabilities or lack of experience and knowledge if they have been given supervision or instruction concerning use of the appliance in a safe way and understand the hazards involved. Children shall not play with the appliance. Cleaning and user maintenance shall not be made by children without supervision.
- Children of less than 3 years should be kept away unless continuously supervised. Children aged from 3 years and less than 8 years shall only switch on/off the appliance provided that it has been placed or installed in its intended normal operating position and they have been given supervision or instruction concerning use of the appliance in a safe way and understand the hazards involved. Children aged from 3 years and less than 8 years shall not plug in, regulate and clean the appliance or perform user maintenance.
- **CAUTION:** Some parts of this product can become very hot and cause burns. Particular attention has to be given where children and vulnerable people are present.
- If the supply cord is damaged, it must be replaced by the manufacturer, its service agent or similarly qualified persons in order to avoid a hazard.
- The heater must not be located immediately below a socket-outlet.
- **DO NOT** use this heater in the immediate surroundings of a bath, a shower or a swimming pool.



- **WARNING:** In order to avoid overheating, do not cover the heater.
- **DO NOT** use this heater with a programmer, timer, separate remote-control system or any other device that switches the heater on automatically, since a fire risk exists if the heater is covered or positioned incorrectly.
- **CAUTION:** In order to avoid a hazard due to inadvertent resetting of the thermal cut-out, this appliance must not be supplied through an external switching device, such as a timer, or connected to a circuit that is regularly switched on and off by the utility.
- Keep furniture, curtains and other fabric material away from the appliance.
- **DO NOT** leave the appliance unattended during use.
- From time to time, check the cord for damage. Never use the appliance if the cord or any part of the appliance shows signs of damage.
- **DO NOT** run the mains cable under carpets, rugs etc.
- **DO NOT** cover or obstruct the heater in any way. Overheating will result if it is accidentally covered.

- Never immerse the product in water or any other liquids.
- **DO NOT** use the appliance outdoors.
- Before cleaning the appliance, ensure it is unplugged from the power and that it is completely cool.
- **DO NOT** clean the appliance with abrasive chemicals.
- Never use accessories that are not recommended or supplied by the manufacturer. It could cause danger to the user or damage to the appliance.
- **DO NOT** insert or allow foreign objects to enter the inlet or outlet vents as this may result in electric shock, fire or damage to the appliance.
- **DO NOT** install the fire using an extension cord.
- Unplug from the mains supply if the appliance is not to be used for long periods.

2.0 APPLIANCE DATA

Weight (kg):	17.0 kg	Supply Cord:	1.8 metres
Dimensions (mm):	H 965 x W 432 x D 152	Fuse:	13Amp
Supply Voltage and rating power:	220-240V a.c. 50Hz, 1800W	Location:	Indoor Use
Heating Elements:	2 x 900Watts (1.8kW)	Lighting:	LED

3.0 ELECTRICAL INSTALLATION REQUIREMENTS

The appliance is supplied with a pre-wired three pin plug (13 Amp fuse rated), and 1.8 metre cable. A standard switched outlet/wall socket, (including earth provision), must therefore be located within this distance, and be easily accessible in order to isolate the supply for maintenance and cleaning. This socket **must not** be mounted behind or above the appliance.

IMPORTANT: THIS APPLIANCE MUST BE EARTHED.

4.0 COMPONENT CHECKLIST

QUANTITY	DESCRIPTION
1	Heater unit
1	Decorative glass facia
1	Remote control handset
1	Instruction Booklet
1	Bag of crystals
5	Fixing screws
5	Wall plugs

5.0 SITE REQUIREMENTS

It should be noted that the appliance creates warm convected air currents. These currents move heat from the room surroundings to, and up the wall surfaces adjacent to the heater.

Installing the heater next to these types of wall coverings or operating the heater where impurities in the air, (such as tobacco smoke) exist, may slightly discolour wall finishing.

If the appliance is to be mounted on a dry lined or timber framed construction then the integrity and ability of the wall to carry the weight of the appliance must be confirmed. It is important in these circumstances that any vapour barrier and/or structural members of the house frame are not damaged.

If you are unsure of the ability of the wall to carry the weight and/or which type of wall fixing to use, you should take professional advice and obtain the correct fixings. Alternatively, find a more suitable wall location.

DO NOT

- mount on a ceiling or floor
- recess any part of the appliance into the wall, or run the supply cable under carpets.
- site any electrical equipment e.g. plasma screen TV sets etc, on the wall below the appliance.
- site in a position where curtains or drapes could cover the appliance, or other soft materials could cover e.g. below a coat rack
- site behind an opening door where mechanical impact/damage could occur
- site where the supply cable would become a trip hazard
- sit, stand or forcefully pull on the appliance
- obstruct, cover or force items into the openings
- use the heater to dry clothes
- site/use in an outdoor location(s)

It is important that the following clearances are maintained from the appliance to combustible materials. These clearances are dependent on the mounting location as defined below:

6.0 CLEARANCES TO COMBUSTIBLE MATERIALS

GB IE

- The minimum distance from the top of the appliance to a ceiling is 127mm
- The minimum distance from the bottom of the appliance to the floor is 500mm
- The minimum distance to the sides of the appliance is 152mm
- The minimum distance to the front of the appliance is 900mm

7.0 UNPACKING THE APPLIANCE

Caution: This appliance is heavy. Always seek assistance whilst unpacking and/or during installation. Read *all* the instructions before continuing to unpack or install this appliance. Carefully remove the appliance from its packaging and lay on the floor with its back surface downward. Check that the remaining packaging contents correlate with the component checklist below. Please dispose of all packaging with care at your local recycling centre.

8.0 INSTALLATION

CAUTION: DO NOT CONNECT THE APPLIANCE TO THE ELECTRICAL SUPPLY AT THIS TIME.

Focal Point Fires plc. assumes absolutely no responsibility for injuries and damages that may occur due to improper installation or handling.

Remove any protective film coatings from the finished/decorative surfaces of the appliance, if any. After having selected the final mounting position of the appliance taking into account the integrity of the wall the firebox of the appliance may be secured to the wall.

To ensure customer safety, be sure to design the installation so that the strength of both the wall and any wall fixings used are sufficient. The appliance should not be installed until all wet plastering and/or dry wall sanding and wall painting has been completed. Do not block the ventilation holes of the appliance. The wall onto which the appliance is installed must be flat. Install only on a vertical surface. Avoid sloped surfaces. Installation onto anything other than a vertical wall may result in fire, damage or injury.

If the appliance is to be mounted on the inner leaf of a conventional cavity brick wall, or a solid wall, then the wall plugs and fixing screws provided may be used. Depending on the condition of the wall it may be necessary to use additional fixings. In this situation, any additional fixings and wallplugs should be of the same size and type as the ones provided.

Select a location that is not prone to moisture and is located at least 900mm away from combustible materials such as curtain drapes, furniture, bedding, paper, etc.

Before installing the appliance, remove the front glass. Remove the 2 bottom securing screws off the appliance. Pull the bottom of the glass front away from the appliance and lift up to disengage the top. Remove and place on a soft non-abrasive surface, refer to Figure 2.

WARNING

The wall where the appliance is to be installed must be capable of long-term support of the total load of the appliance. Measures should also be taken to ensure sufficient strength to withstand the force of earthquakes, vibration and other external forces. Plasterboard alone is not considered to be a structural material. It is not recommended to rely on plasterboard fixings alone to support the weight of the appliance.

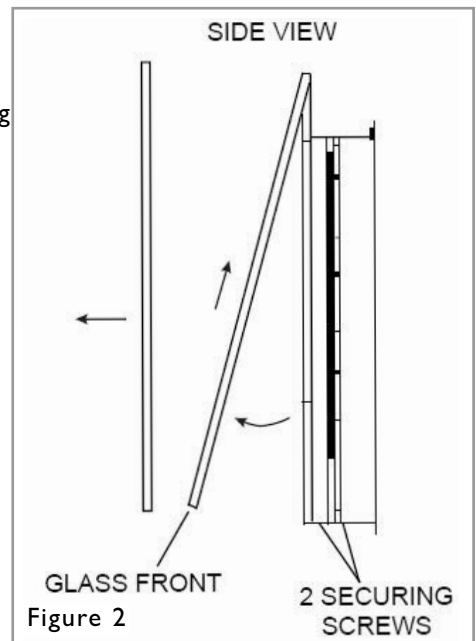
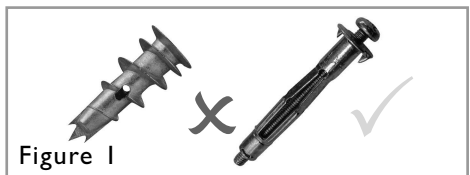

Have two people hold the appliance against the wall to determine the final location.

Mark out 5 drill hole locations, refer to Figure 3.

Using a 6mm drill bit, drill the 5 holes marked on the wall and fit with the supplied wall plugs, have at least one screw in a wall stud. **NOTE:** If hole locations are on studs, you do not need to drill or use wall plugs, simply apply screws directly into studs.

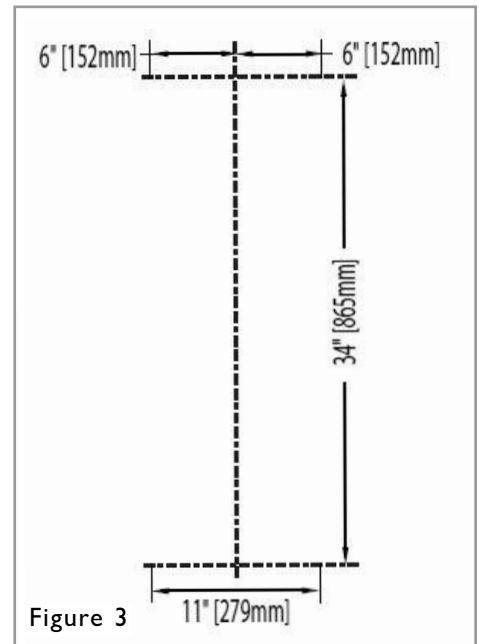

Lift the appliance onto the wall, align with the 5 pre-drilled holes. Secure the appliance to the wall, refer to Figure 4.

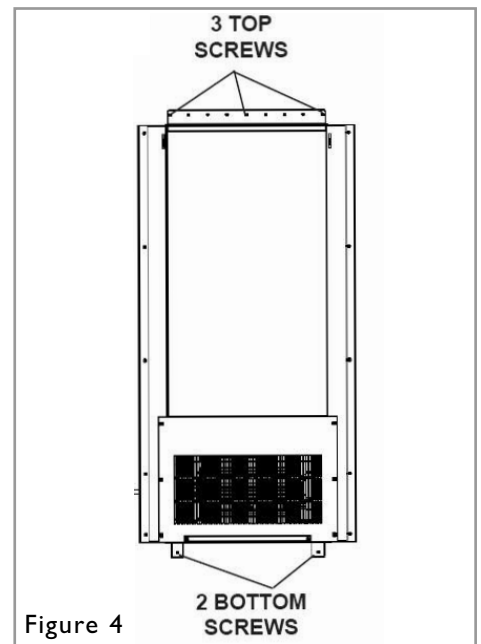

Sprinkle the crystal embers along the ember bed, refer to Figure 5.

Install the glass front onto the appliance and secure with the two screws.

Check the appliance for stability ensuring it will not pull free from the wall.



8.1 REMOVING THE GLASS FRONT

GB IE

Remove the 2 bottom securing screws off the appliance. Pull the bottom of the glass front away from the appliance and lift up to disengage the top.

Tilt the glass front away from the unit. Slightly pull down on the glass to release from the top catch.

Remove and place on a soft non-abrasive surface, as shown in the illustration.

Reverse steps to reinstall the glass front.

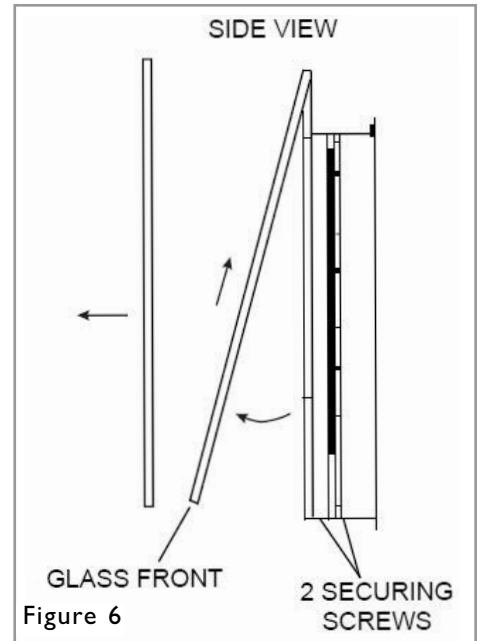

8.2 INSTALLING THE CRYSTAL EMBERS

The glass front must be removed and the appliance must be mounted in its final location before the crystal embers are installed.

A. Cleaning the crystals is recommended: Crystal embers may have a fine oil residue that needs to be cleaned prior to installation. Clean the crystal with mild dish soap, drain, rinse thoroughly and dry before placing into the tray.

B. Carefully place crystal embers into the bottom tray on the front of the appliance as illustrated. Apply an even layer from side to side.



9.0 OPERATING THE APPLIANCE

The control panel is located on the left side of the appliance as illustrated.

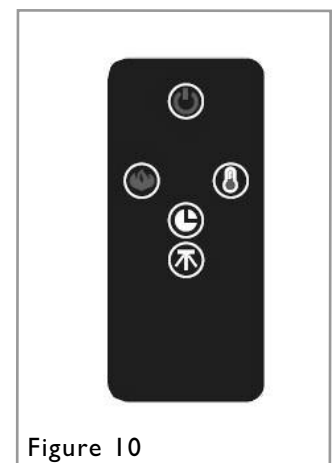
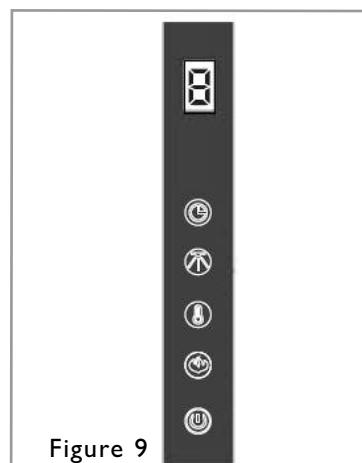
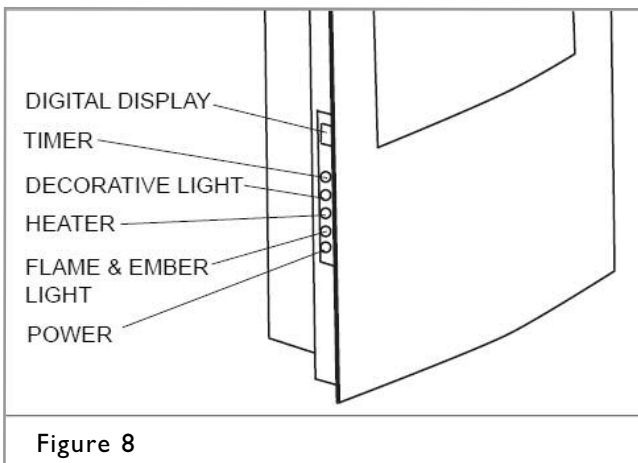

9.0 OPERATING THE APPLIANCE

GB IE



POWER ON/OFF

Turns the appliance ON/OFF.



FLAME & EMBER LIGHT CONTROL

Controls flame ON/OFF and the ember light colours; Orange - Blue - Purple - Cycle - Off (LOOP) Press button for 5 seconds to lock or unlock the heater.



HEATER CONTROL

Turns the heater ON/OFF. Hold button for 5 seconds and wait for the display to flash.

0. 18°C/ 64°F - 1. 19°C/ 66°F - 2. 20°C/ 68°F - 3. 21°C/ 70°F - 4. 22°C/ 72°F - 5. 23°C/ 74°C - 6. 24°C/ 76°F - 7. 25°C/ 78°F - 8. 26°C/ 80°F - 9. 27°C/ 82°F - N. ON (LOOP).



BACK LIGHTS

Controls back lights ON/OFF light colours; Orange - Blue - Purple - Cycle - Off (LOOP).



TIMER

The timer can be programmed to run the appliance/ heater for specific lengths of time (1 hour minimum to 9 hours maximum).



DIGITAL DISPLAY

Digital display of appliance functions.

Remote Control

The fire is supplied with an IR multifunction remote.

Before the remote will operate the plastic insulating sheet needs to be removed.

Battery Replacement

Battery Requirements: CR2032

1. Locate and remove the battery bracket.
2. The battery has two sides, one with a button feature, and the other is flat.
3. Insert the battery with the button side down into the battery bracket, making sure the battery is firmly seated.

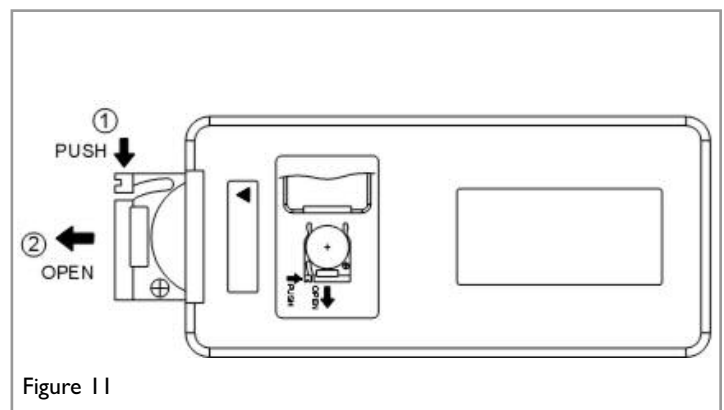

Figure 11

10.0 SAFETY CUT-OUT SYSTEM

This product has one non-self-resetting overheat protection device (thermal cut-out) which will activate if the air inlets or outlets are obstructed. For safety reasons the fire will NOT switch on again automatically, the following procedure must be carried out before the fire can be operated.

NOTE: The visual effect will remain operational if the cutout is activated, only the fan heater is prevented from working.

Switch OFF the appliance **at the wall socket or outlet**. Leave the fire OFF for a period of no less than 10 minutes, ensuring all obstructions are removed. Switch the appliance ON **at the wall**. Ensure the appliance is turned ON at the control switches. If the fire fails to operate correctly, repeat the above procedure. If an attempt to switch on the appliance is made before the safety cutout has reset, the appliance may cutout for a further period of time. If the sequence has been followed correctly and the appliance still fails to function, check the fuse in the wall outlet. If this is not the cause, call an electrician or maintenance engineer.

11.0 CLEANING AND MAINTENANCE

GB IE

ALWAYS DISCONNECT THE APPLIANCE AT THE SUPPLY OUTLET SOCKET BEFORE UNDERTAKING ANY CLEANING.

Except for periodic cleaning of dust, there are no specific requirements for care, other than regular cleaning of the general appliance. A wipe with a dry cloth is normally sufficient. **DO NOT** use abrasive cleaners as they can damage the finish. Make sure the heater outlet grille (located on the top panel), and the air inlet mesh grilles (located on the sides and base panel) are kept clear of dust, pet hair and other airborne household matter. These should be vacuum cleaned periodically using a brush attachment.

GLASS FACIA PANEL - This should only be cleaned using a suitable glass cleaner. Test on a small area first.

12.0 SERVICING

There are no internal user serviceable parts.

Check regularly for security of wall fixings as appropriate. Also check security of supply cable and connections. If the supply cable becomes damaged, it must be replaced by a service agent or competent person, such as a qualified electrician.

This appliance is supplied with a 3 pin plug fitted with a 13 Amp fuse. Should the fuse require replacing, it must be replaced with a fuse rated at 13 Amp. In the event of the mains plug being removed/ replaced for any reason, please note : **IMPORTANT:** The wires in the mains lead are coloured in accordance with the following code:

Blue - Neutral

Brown - Live

Green/ Yellow - Earth

As the colours of the wires in the mains lead of this appliance may not correspond with the colour markings identifying the terminals in your plug, proceed as follows. The blue wire must be connected to the terminal marked with an N or coloured black. The brown wire must be connected to the terminal marked with an L or coloured red. The green/yellow wire must be connected to the earth terminal which is marked with an E or with the earth symbol. **WARNING:** Never connect live or neutral wires to the earth terminal of the plug.

NOTE: If a moulded plug is fitted and has to be removed take great care in disposing of the plug and severed cable, it must be destroyed to prevent engaging into a socket.

Refer to Section 2.0, Appliance Data for fuse specification. Excluding fuses, use only genuine manufacturers spare parts available from your supplier.

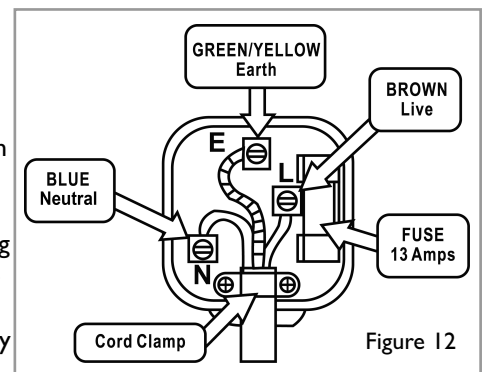

13.0 APPLIANCE DIMENSIONS

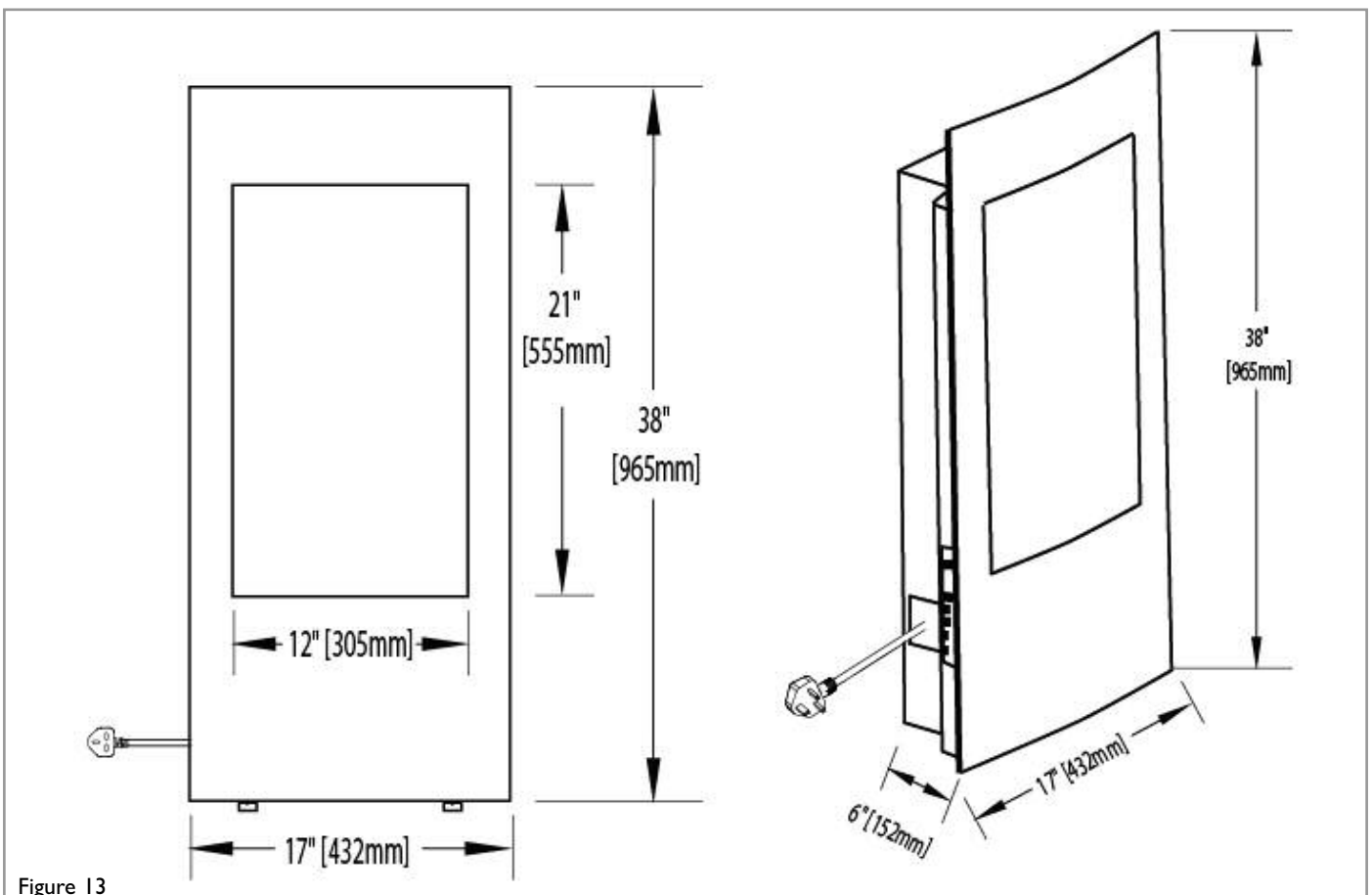

Figure 13

Registration is not required.

Appliances purchased prior to 1st February 2009, and those specifically marked as '1 year guarantee' on this website, are guaranteed for one year from the date of purchase, provided that the following three terms and conditions are adhered to:

1. For any claim to be made within 1 year from date of purchase you will be required to provide and supply us with your original proof of purchase.
2. Your gas fire must have been commissioned by Gas Safe registered installer, evidence of which you must provide together with the registration number.
3. All appliances must have been installed and operated in accordance with the manufacturer's instructions.

3 Year Guarantee Terms and Conditions

Please be advised that the 3 year guarantee only covers products purchased on or after 1st February 2009.

The 3 year guarantee is only applicable to purchases made through an authorised stockist/retailer. Please see our website for a list of authorised stockists. Any purchase(s) made through an unauthorised stockist(s) will be eligible for a statutory 1 year guarantee.

For all gas fires purchased the 3 year guarantee commences from the date of purchase, provided that the following 4 terms and conditions are adhered to:

1. For any claim to be made within the 3 years from date of purchase you will be required to provide and supply us with your original proof of purchase.
2. Your gas fire must have been commissioned by Gas Safe registered installer, evidence of which you must provide together with the registration number.
3. Your appliance must have been serviced annually by Gas Safe registered installer, evidence of which must be provided, such as the receipt.
4. Purchase(s) must be made through an authorised stockist/retailer.

Please note all consumable items such as any ceramics including; coals, pebbles, the matrix, front strips, side cheeks, rear panels and tapered rear panels are not covered by the 3 year guarantee.

During the guarantee period any product or component which is proved to be faulty or defective in manufacture, will be repaired or replaced free of material and labour charges, providing that we have authorised or carried out the repair or replacement.

We will not accept or reimburse the costs of any third party who undertakes any work carried on the product or fits parts, unless we have approved such work in advance of it being carried out.

The guarantee period will not be extended even if we repair or replace any product or part.

For all electric fires purchased the 3 year guarantee commences from the date of purchase, providing that you can supply the proof of purchase. This does not cover consumable items such as pebbles, coals or light bulbs. Purchase(s) must be made through an authorised stockist.

Making a claim:

Making a claim is easy. If you wish to make a claim under our guarantee and all the terms and conditions for your product have been met then please submit the following information for the attention of the 3G Service Department to the address below.

Alternatively, you can email or fax.

Superior Fires, 3G Service Department, Reid Street, Christchurch, Dorset, BH23 2BT.

Email: service@superiorfires.co.uk,

Fax: 01202 499326.

Details required:

1. Name, full address including postal code and contact telephone number.
2. A copy of your proof of purchase e.g. receipt or bank statement.
3. Original installers Gas Safe registration number (gas fires only).
4. Annual service receipt for every 12 months (gas fires only).

Please note that this does not affect your statutory rights.



Waste electrical products should not be disposed of with household waste. Please recycle where facilities exist. Check with your local authority or retailer for recycling advice.

As our policy is one of continuous improvement and development, we therefore hope that you will understand we must retain the right to amend details and/or specifications without prior notice.