

INSTALLATION & USER INSTRUCTIONS

FULL DEPTH RADIANT/CONVECTOR INSET GAS FIRE

SUPERIORFIRES
UNCOMPROMISING QUALITY

Superior Fires
Christchurch, Dorset BH23 2BT
Tel: 01202 588 632
Fax: 01202 499326
www.superiorfires.co.uk
e : info@superiorfires.co.uk

MODELS COVERED BY THESE INSTRUCTIONS

WHATLEY RADIANT ELEGANCE BRASS NG
WHATLEY RADIANT GROVE BRASS NG
WHATLEY RADIANT GROVE BLACK FRAME NG
WHATLEY RADIANT GROVE CHROME NG
BELROSE RADIANT EDWARDIAN BLACK NG
BELROSE RADIANT EDWARDIAN CHROME NG
BELROSE RADIANT SOHO CHROME NG
BELROSE RADIANT VICTORIAN BLACK NG
BELROSE RADIANT VICTORIAN CHROME NG
CASONA RADIANT COAL NG
CASONA RADIANT PEBBLE REMOTE NG
WALTHER CONVECTOR ELYSEE BRASS NG
WALTHER CONVECTOR GROVE BRASS NG
WALTHER CONVECTOR GROVE CHROME NG
MALLORY CONVECTOR EDWARDIAN CHROME NG
MALLORY CONVECTOR VICTORIAN CHROME NG

F500391
F500392
F500393
F500394
F500395
F500396
F500397
F500398
F500399
F500400
F500401
F500402
F500403
F500404
F500405
F500406



BS7977-1 : 2009
BS EN 509 : 2000
KM579168



WHATLEY RADIANT GROVE



WHATLEY RADIANT ELEGANCE



WHATLEY RADIANT GROVE



BELROSE RADIANT EDWARDIAN



BELROSE RADIANT SOHO



BELROSE RADIANT VICTORIAN



CASONA RADIANT COAL



CASONA RADIANT PEBBLE



WALTHER CONVECTOR ELYSEE



WALTHER CONVECTOR GROVE



MALLORY CONVECTOR EDWARDIAN



MALLORY CONVECTOR VICTORIAN

Please note : Except where otherwise stated, all rights, including copyright in the text, images and layout of this booklet is owned by Focal Point Fires plc. You are not permitted to copy or adapt any of the content without the prior written permission of Focal Point Fires plc.

Please note : All colour/finish variants are not shown.

All instructions must be handed to the user for safekeeping.

Revision A - 10/11

© 2011 Focal Point Fires plc.

Section	Contents	Page No.	Section	Contents	Page No.
1.0	Important Notes	2	12.1	Operating the Fire (Manual control)	9
2.0	Appliance Data	3	12.2	Operating the Fire (Slide control)	9
3.0	Installation Requirements	3	12.3	Operating the Fire (Remote control)	9
4.0	Site Requirements	3	12.4	Spark Gap	10
4.1	Debris Collection Space	4	12.5	Operating Pressure (Manual models)	10
5.0	Ventilation	5	12.6	Operating pressure (Slide & Remote models)	10
6.0	Pre Fabricated Flue Boxes	5	12.7	Flue Spillage Monitoring System	10
7.0	Unpacking the Appliance	5	12.8	Testing for Spillage	10
7.1	Component Checklist	5	12.9	Briefing the customer	11
8.0	Preparing the Appliance	6	13.0	Servicing	11
9.0	Preparing the Opening	7	13.1	Cleaning the Ceramics	11
10.0	Gas Supply Routing	7	13.2	Removing the Burner	12
11.0	Fitting the Firebox	7	13.3	Servicing the Burner	12
11.1	Installation by Cable Fixing Kit	8	13.4	Pilot Assembly	12
11.2	Gas Connection	8	13.5	Removing the Firebox	12
11.3	Fuel Bed Layout	8	13.6	Replacing the Batteries (Slide control versions)	12
11.4	Fitting the Firefront / Frame	8	13.7	Replacing the Batteries (Remote control versions)	12
12.0	Testing and Commissioning	8	14.0	Troubleshooting Guide	13

1.0 IMPORTANT NOTES

- This appliance is an Inset Decorative Fuel Effect appliance which provides radiant warmth utilising the latest type burner technology.
- The fire is designed to suit various types of fireplaces and natural draught flues as detailed in this manual.
- The appliance must be installed by a competent person in accordance with Gas Safety (Installation and Use) Regulations 1998. It is strongly recommended that a GAS SAFE registered engineer be used for this purpose.
- Read all these instructions before commencing installation.
- This appliance must be installed in accordance with the rules in force and used only in a sufficiently ventilated space.
- The appliance is designed for installation on to a non-combustible hearth of at least 300mm depth.
- This appliance is factory set for operation on the gas type, and at the pressure stated on the appliance data plate.
- In the event of gas leakage from the appliance, the gas supply must be turned off at the nearest isolating valve.
- The appliance must be installed in accordance with the following:
 - Manufacturers' Instructions.
 - The Building Regulations issued by the Department for Communities and Local Government, the Building Standards (Scotland) (Consolidation) Regulations issued by the Scottish Development Department.
 - Relevant British Standards insofar as the relevant areas are not covered by these instructions.
 - For Republic of Ireland, reference should be made to the current edition of IS813 (the relevant standards governing installation).
- Failure to comply with the above could lead to prosecution and deem the manufacturer's warranty invalid.
- The appliance is designed to fit various types of situations as described in sections 3.0 and 4.0.
- It should be noted that heaters create warm air currents. These currents move heat to wall surfaces next to the heater. Installing the heater next to vinyl or cloth wall coverings or operating the heater where impurities in the air (such as tobacco smoke, candle smoke etc.) exist, may cause the walls to become discoloured.
- **WARNING:** The manufacturer of this appliance considers all surfaces as working surfaces with the exception of the control knob and ash pan door. Where young children, pets, the elderly or infirm are concerned, a suitable fireguard should be used.
- Consult ALL instructions before installation and use of this appliance.
- This appliance is free from any asbestos material.
- Refractories and fuel bed are constructed from ceramic fibre.
- Slide control models : These appliances feature a battery-operated control system, and under normal usage will need a new battery approximately every twelve months.
- Burner/spark generator requirements - 1 x 'PP3' type (9 volt)
- Refer to the appropriate section of these instructions for details of how to change the battery.
- Remote control models : This appliance features a battery-operated remote control system, and under normal usage will need new batteries approximately every twelve months.
- Remote control Handset requirements - 1 x 'PP3' type (9 volt)
- Receiver/motor unit requirements - 4 x 'AA' type (1.5 volt)
- Refer to the appropriate section of these instructions for details of how to change the batteries.

2.0 APPLIANCE DATA

GB IE

Model	Destination Country	Cat	Operating Pressure (±2.0 mbar)				Max Energy Input (kW)		Min Energy Input (kW)	
			G20	G25	G30	G31	Gross	Net	Gross	Net
Natural gas										
Manual control models	GB - IE	l ₂ H	20	-	-	-	6.8	6.1	3.5	3.15
Slide control models	GB - IE	l ₂ H	15.8	-	-	-	6.8	6.1	3.5	3.15
Remote control models	GB - IE	l ₂ H	15.8	-	-	-	6.8	6.1	3.5	3.15

Please see Data Badge affixed to appliance for current data. This appliance is for use only with the gas type, and at the pressure stated on the appliance Data Badge, and is for decorative purposes.

Specifications	Manual Control Models	Slide control models	Remote control models
Main burner injector	Stereo size 76	Stereo size 82	Stereo size 81
Oxypilot (Natural Gas Models)	SIT 9081	SIT 9081	SIT 9081
Gas Control (All Models)	Copreci 21400/342	Teddington TESA 3173/011	Mertik Maxitrol GV30 series
Gas Inlet	All models - 8mm compression - Inlet restrictor elbow		
Ignition	Double-action piezo Spark	Piezo Spark	Piezo Spark
Spark Gap	3.5 - 4.5mm	3.5 - 4.5mm	3.5 - 4.5mm
Flue specification	All models - 225mm x 225mm (9in x 9in) brick or stone. 125mm (5in) minimum diameter lined brick or stone. 125mm (5in) minimum diameter twin wall flue conforming to BS 715. Pre-cast block flue complying with BS 1289 or BS EN 1858.		

3.0 INSTALLATION REQUIREMENTS

This appliance **MUST NOT** be installed into a room containing a bath or shower, or where steam may be present. The fire has been designed to fit into a builders' opening or fireplace conforming to BS 1251 (and meeting certain dimensional requirements), or a suitable flue box complying with the constructional requirements of BS 715. The flue box must be installed onto a suitable non-combustible insulating surface at least 12mm thick, covering the entire base area of the box. The flue must have an effective height of at least three metres, as measured from the hearth to the top of the flue. Any flue damper plates or restrictors should be removed and no other restriction fitted to the flue. Where removal is not practical, the restriction must be fixed in the fully open position.

A natural draught flue system is required, and if previously used for solid fuel or oil burning, the flue and chimney must be swept prior to appliance installation. The flue must be checked before installation by using a smoke pellet or similar to ensure proper draw and that leakage is not evident at any joints. Repair and re-test as necessary before the appliance is installed. The flue must be connected to only one fireplace, and the flue must not vent more than one appliance (i.e. not shared with a gas back boiler). There must be no opening in the flue apart from the one that the appliance is installed into, and the one venting the gases into the air. A suitable terminal may be fitted, such as class GCI, as regulations allow.

Radiant models only : This appliance has been tested for use in a pre-cast block flue complying with BS 1289. In accordance with BS EN 1858, pre-cast flues built with directly plastered faces (front or rear) are not correctly installed as to ensure proper operation with **any** type of gas fire. In some instances of this flue construction, temperature cracking of the surface plaster may occur through no fault of the appliance. An air gap or some form of insulation material should be installed to prevent normal flue temperatures from damaging wall surfaces. Pre-cast flues must be checked for mortar fangs and correct installation of joints, flue sections in loft space and terminals.

Convactor models only : Convactor models are not suitable for installation on pre-cast flues.

All models : These appliances have been tested for use with circular flues of a minimum internal diameter of 125mm. This appliance is suitable for use with a "lightweight" surround and back panel of 150°C minimum rating.

4.0 SITE REQUIREMENTS

The fireplace opening should be inspected and repairs made where necessary. Any chair brick or fireback may be left in situ, providing that the dimensional requirements for debris collection space and spigot clearances are met. See figure 1.

Radiant models only : The opening **WIDTH** and **HEIGHT** dimensions should be between 375mm and 450mm wide, and 540mm to 575mm high. The spigot outlet of the fire is 570mm high, but should fit into the gather at the top of the fireplace as the appliance is fitted (see figure 10). Any modifications to the fireplace opening must be to a height of 570mm min. Opening **DEPTH** should be 200mm or greater for a clay/cement lined or pre-cast flue which is new, unused, or previously used only with a gas appliance. **DEPTH** should be 240mm or greater for a flue used for solid fuel or oil burning appliances. Opening **DEPTHS** include any plaster or infill panels which form part of the installation.

Convactor models only : The opening **WIDTH** and **HEIGHT** dimensions should be between 390mm and 440mm wide, and 545mm to 575mm high. Opening **DEPTH** should be 267mm or greater for a clay/cement lined flue which is new, unused, or previously used only with a gas appliance. **DEPTH** should be 307mm or greater for a flue which has been used for solid fuel or oil burning appliances. Opening **DEPTHS** include any plaster or infill panels which form part of the installation. Opening **DEPTHS** include any plaster or infill panels which form part of the installation.

All models : This appliance requires a natural draught flue system which may be one of the following;

- 225mm x 225mm (9in x 9in) brick or stone.
- 125mm (5in) minimum diameter lined brick or stone.
- 125mm (5in) minimum diameter twin wall flue conforming to BS 715.
- Pre-cast block flue complying with BS 1289 (**Radiant models only**).

Any existing under grate draught device must be sealed off. The opening wall must be non-combustible. The appliance requires a hearth with non-combustible surface of at least 12mm thick. The top surface must be at least 50mm above the surrounding floor level, or be surrounded by a raised edge or fender 50mm high.

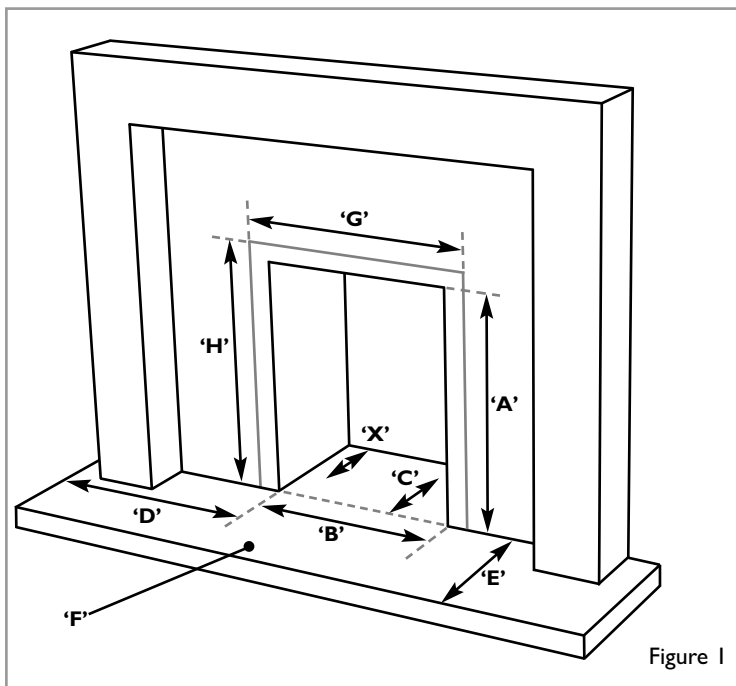

Note : *dimensions in italics refer only to convector models.*

- 'A'. Opening height: 540mm min/575mm max (*545mm min*).
- 'B'. Opening width: 375mm min/450mm max. (*390mm min/440mm max*)
- 'C'. Mounting depth: 180mm (*247mm*).
- 'D'. Hearth must extend minimum of 150mm either side of the opening.
- 'E'. Hearth must extend minimum of 300mm in front of the opening.
- 'F'. Non-combustible hearth must be a minimum of 50mm in height, or be surrounded by 50mm high fender.
- 'G'. 470mm, this area must be flat and vertical to ensure a good seal.
- 'H'. 585mm, this area must be flat and vertical to ensure a good seal.
- 'X'. Debris collection space - See section 4.1.

To enable the products of combustion to be cleared properly up the flue, the outlet at the back of the appliance must have a 50mm minimum clearance between it and the back wall of the opening or any other obstruction. The area immediately above the outlet must form a smooth path into the flue.

Any type of fire surround used with this appliance must be adequately sealed to the wall and floor.

A combustible shelf may be fixed to the wall above the fire, providing that it complies with the dimensions given below.

Maximum depth of shelf	Minimum distance from finished hearth surface to underside of shelf
100mm	745mm
150mm	845mm
203mm	895mm

A non-combustible shelf may be fitted to within 10mm of the top edge of the fireframe. Combustible materials, such as wood, may be fitted to within 100mm of either side of the fireplace opening, providing the forward projection does not exceed 100mm. Any combustible side walls must be at least 500mm to the side of the radiant heat source. As with all heating appliances, any decorations, soft furnishings, and wall coverings (i.e. flock, blown vinyl and embossed paper) positioned too close to the appliance may discolour or scorch. Radiant models have a mounting depth of 180mm. In accordance with BS 5871 part 2, minimum debris collection volumes are required behind the installed appliance. These are shown below and as dimension 'X' in figure 1.

4.1 DEBRIS COLLECTION SPACE

CLAY/CEMENT LINES OR BLOCK FLUE WHICH IS NEW, UNUSED, OR PREVIOUSLY ONLY USED WITH A GAS FIRE.
X Dimension = 20mm

UNLINED FLUE OR CHIMNEY WHICH HAS BEEN PREVIOUSLY USED FOR A SOLID FUEL OR OIL BURNING APPLIANCE
X Dimension = 60mm

No purpose provided ventilation is normally required for this appliance. The requirements of other appliances operating in the same room or space must be taken into consideration when assessing ventilation. If spillage is detected when commissioning the appliance, then amongst other problems there may be insufficient natural ventilation for correct operation of the flue. If the appliance does not spill with the windows open, but spillage is detected with the windows closed, this demonstrates a lack of natural ventilation. If spillage is still detected with the windows open, the flue is at fault. Installation of an air brick is the best solution to lack of ventilation. Any ventilation fitted must comply with BS 5871 part 2 and BS 5440 part 2. Vents fitted under or within the immediate vicinity of the appliance must not be used as adverse effects to the operation of the ODS may occur. Spillage detected during commissioning is almost always a result of poor flue performance that cannot be corrected by any amount of ventilation. For Republic of Ireland ventilation may be required, see IS 813, ICP3, IS 327, and any other rules in force.

6.0 PREFABRICATED FLUE BOXES

This appliance can be fitted into a number of proprietary flue boxes provided that the minimum dimensions shown in figure 2 are complied with.

Constructional Note: The frame of the fire, any back panel or other infill panels, and the flue box must be sealed together so that there is no possibility of leakage between them. Adequate clearances to combustible materials (e.g. false chimney breast construction) must be maintained.

The manufacturers' instructions for fitting the prefabricated box shall be complied with at all times. To fit the fire using the cable fixing kit, some minor adaption may be necessary for certain flue boxes. A check should be made to ensure the firebox does not obscure the flue box outlet. The firebox, base of the flue box, and hearth below may be drilled to allow plugs and screws to secure installation. It is important that the sealing requirements of the appliance are met at all times and that the flue box is well sealed to any back or infill panel. **Note:** The DEPTH dimension is inclusive of any back or infill panel.

Figure 2

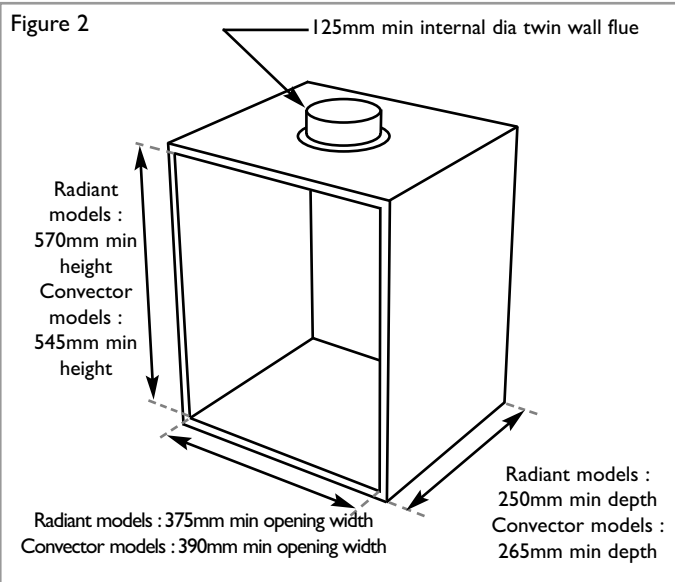

7.0 UNPACKING THE APPLIANCE

Stand the carton the right way up, cut the strapping bands and remove the top endcap. Read **all** the instructions before continuing to unpack or install this appliance.

Remove the box containing the firefront, and the bags containing the ceramic components. Remove the cardboard packing pieces, and any other bags or boxes containing fittings or other parts. When all loose parts have been removed, the outer sleeve may be lifted off to reveal the appliance. Check that the components supplied correlate with the component checklist given in section 7.1. Please dispose of all the packaging materials at your local recycling centre.

7.1 COMPONENT CHECKLIST

QUANTITY	DESCRIPTION
1	Firebox and burner tray assembly
1	Decorative cast frame and ashpan (Edwardian, Victorian and Soho models)
1	Decorative extruded frame with detachable control cover (Casona models)
1	One piece or three piece decorative trim (Dependant on model)
1	Cast firefront (Elegance, Elysee and Grove models)
1	Moulded ceramic fibre combustion matrix
1	Moulded ceramic front strip
16	Individual ceramic coals (Coal models only)
16	Individual ceramic pebbles (Pebble models only)
9	Individual ceramic logs (Log models only)
1	Slide control knob and M4 Nyloc nut (Slide control models only)
1	Remote handset (Remote models only)
1	Cable fixing kit; 2 cables, 2 tensioners, 2 cable clamps, 4 eyebolts, 4 wall plugs
1	Sealing grommet
3	Lengths of adhesive sealing strip
1	Self tapping screw pack; 4 No8 x 5/16
1	Set of manufacturers instructions

Note: Ensure that the gas supply is isolated before commencing installation of the appliance.

The fireplace opening and environment must be in compliance with specifications laid down in the appropriate sections of these instructions.

Remove the appliance from its carton as described previously and stand upon a dust sheet or similar. Place the decorative frame, coals, ceramics and fixings safely to one side. Remove the burner from the assembly by removing the retaining screws.

Slide control models : Remove the slide control linkage connecting screw.

The tray is now free, and may be lifted away.

RADIANT PANELS (Radiant models only): The three radiant panels may now be fixed inside the firebox. Select the patterned side of each panel and insert as follows;

Lay the firebox on its back. Lay the tapered panel onto the rear face of the firebox.

The side panels should be fitted by inserting their front edges into the pre-fitted retaining brackets on the front face of the firebox. Gently align the side panels with the side of the firebox as shown in figure 3, over the top of the back panel already in place.

Make sure that the side panels are pushed **up** firmly to the roof of the firebox, and **back** firmly to retain the tapered panel. Make small adjustments to line up the mortar lines if required. Secure the side panels using the small 'L' shaped brackets and screws provided (figure 4). The screws should locate into the pre-punched holes in the sides of the firebox.

SUPPLY PIPE ENTRY (All models) : Knockout holes are provided in the rear and sides of

the firebox for use where concealed pipework is required. Where necessary, knock out the appropriate hole with a sharp tap from a hammer, and fit the rubber grommet supplied. A small incision can now be made in the rubber to slip snugly around the outside of the pipe and sleeving. **Do not install or use the appliance without the seal in place.** If a hole is inadvertently opened, reseal with an intact grommet. Failure to fit the seal correctly will cause flue suction to act upon the area under the burner, resulting in poor performance and intermittent cutting out of the burner.

Slide controls models : The control knob is supplied as a loose part. Insert the control knob into the hole in the top of the slide control spindle (Figure 5). Secure the control knob in position using the M4 nyloc nut provided.

SPIGOT RESTRICTOR : If installing the fire into a Class 1 or good Class 2 flue, simply bend up (stitch bend join) the spigot restrictor into position in the flue outlet of the fire as shown in figure 6.

You MUST remove (or bend down fully) the spigot restrictor and re-test if the appliance fails a spillage test during commissioning.

SEALING STRIPS : Apply the self adhesive sealing strips to the back of the fireframe as shown in figure 8 to give a continuous seal.

Figure 3

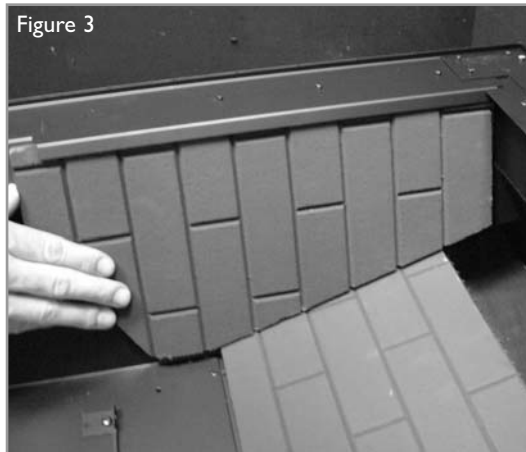

Figure 4

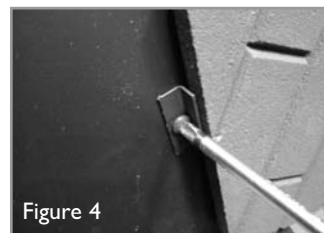

Figure 5

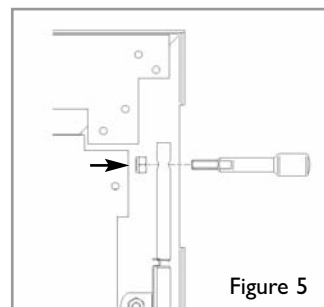

Figure 6



Figure 7



Figure 8



Before installing the fire, check the flue using a smoke pellet. All of the smoke should travel up the flue and exit correctly from the terminal. If problems are found, DO NOT fit the fire until corrective action is completed. Protect the decorative hearth whilst pushing the firebox in and out of the opening. Part of the packaging will make an ideal hearth saver pad. Before running the gas supply into the opening, offer up the firebox to the fireplace to check the fit is good. Angle the firebox as shown in figure 9 or adjust the spigot outlet as described in part 10.0 of these instructions. Ensure that it slides in correctly, the sealing face sits flat and square to the wall or infill panel, and that the base is firm on the floor of the opening as no leaks are permissible here.

At this stage it is essential to ensure that the spigot outlet of the fire is not restricted in any way. Remove the firebox and take any necessary measurements before making good and preparing for final installation.

CABLE FIXING : For fixing of the fire by the cable method, see the relevant section. The cable fixing locations should be marked on the back of the opening and the holes drilled. Fit the wall plugs and eyebolts to these holes.

SCREW FIXING : For fixing by screw, mark and drill the fireframe or base, and the relevant points in the opening or on the wall. Wall plugs will again be required. Pre-punched holes are not provided for this purpose to allow you to choose the optimum positions.

GAS SUPPLY : Following preparation for the fixing method, the concealed gas supply, where required, can now be put into place. Refer to the gas supply section for suggested pipe routes. The ends of the sleeving in which the gas pipe is run should be sealed. The ends of the 8mm supply pipe should be temporarily sealed to prevent the ingress of debris during fixing.

10.0 GAS SUPPLY ROUTING

When the opening is ready for installation of the fire, the gas supply may be routed as per the examples shown in figure 9.

IMPORTANT - Wherever a concealed connection is made a rubber grommet must be used to seal the firebox.

The gas pipe must be suitably protected where it passes through fireplace openings. Any sleeving should be sealed to the pipe at its ends. This appliance is fitted with an inlet restrictor elbow. Using 8mm diameter pipe, connect the appliance to the gas supply point. The appliance must be fitted with rigid or semi-rigid pipe of 8mm external diameter. The appliance is factory fitted with an inlet restrictor elbow. Use a minimum length of 8mm pipe, less than 1.5m where possible, as a long run of pipe may cause an unacceptable drop in the supply pressure.

The open end of the supply pipe should be sealed temporarily during the installation of the firebox to prevent the ingress of dirt and dust.

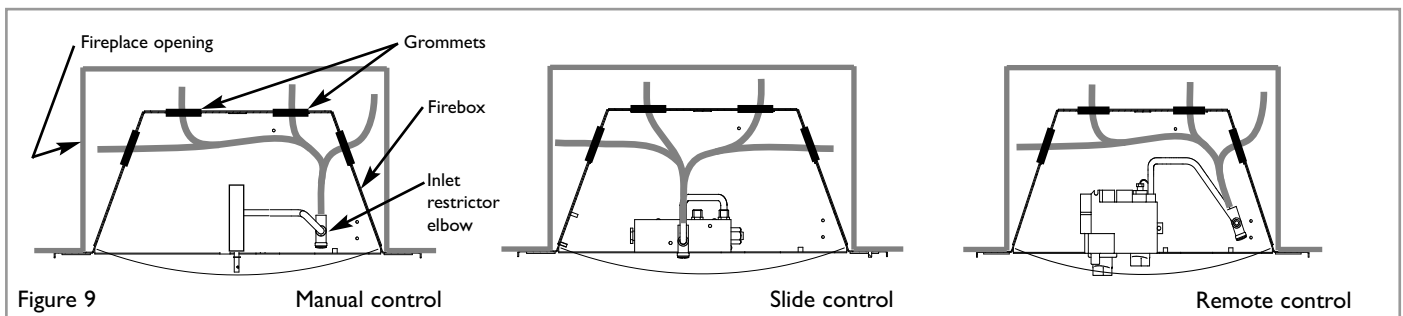

11.0 FITTING THE FIREBOX

Radiant models only :

To fit the firebox, first check the firebox fits correctly into the opening. For openings between 545mm and 565mm in height it will be necessary to insert the upper part of the firebox first, followed by the lower as shown in figure 10.

If it is still not possible to fit the firebox into the opening then remove the outlet deflector screws using a screwdriver, bend the outlet deflector down and partly insert the firebox. **Now push the outlet deflector back up to the original position** under the lip of the fireplace opening and secure with the screws.

The fire is designed to operate correctly with the spigot raised and screwed in its original position and spillage problems may arise by not realigning correctly once fitted. Secure the firebox by drilling and screwing down the frame or base of the firebox, or use the cable fixing method.

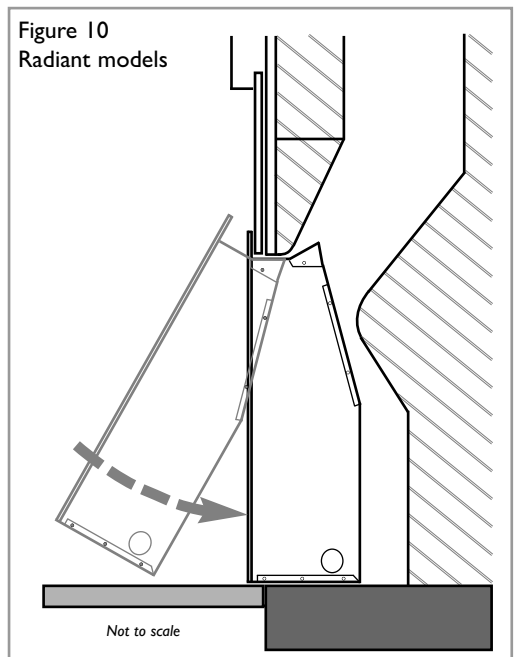

11.1 INSTALLATION BY CABLE FIXING KIT

GB IE

All models : Drill four holes using a 8mm masonry bit to a depth of 42mm in the positions shown in figure 11. If the fireplace configuration does not allow the exact layout given, the eyebolts should be positioned as close to the correct layout as possible.

Before finally fitting cables, ensure the self adhesive sealing strips are in position on the back of the appliance frame. The fireframe must be sealed evenly to the fireplace opening all around the periphery.

Thread the tensioning cables through the holes in the top of the firebox, then the eyelets, and finally through the lower holes in the back of the firebox, as shown in figure 12.

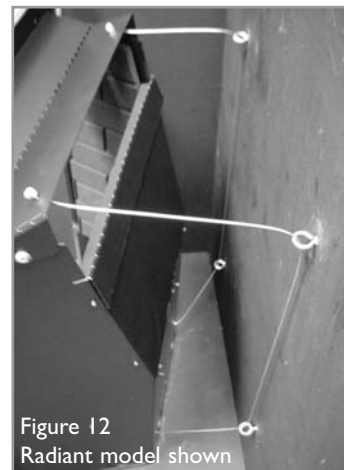
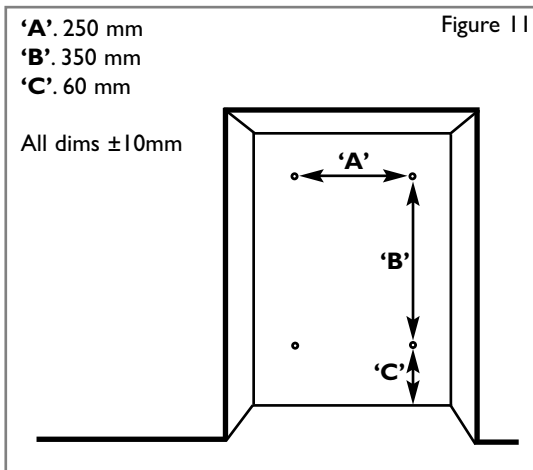

Figure 12
Radiant model shown

Note : The burner must be removed as per relevant section to gain access to the cable adjusters.

Push the appliance back into the fireplace, centralise, and pull the loose tensioning cables through the holes into the firebox. You may need to temporarily adjust the outlet deflector at this point as described in section 11.0 of these instructions. Thread the tensioner bolts onto the cables, with the nuts screwed down close to the tensioner head. Slide the screwed nipple onto the cable, pull cable tight, and tighten nipple.

The tension of the cable may now be adjusted by using a suitable spanner on the tensioner nuts to pull the appliance tightly against the fireplace opening. Visually inspect the seal and reseal if necessary.

Do not cut off excess cable. Surplus cable must not be cut off, as it will be impossible to refit the fire after servicing. Coil up the surplus cable, and locate at rear of firebox as shown in figure 13. If running a concealed gas supply, ensure grommets are secure around incoming pipes.



Figure 13

11.2 GAS CONNECTION

Important Note: Check the thermocouple nut connection into the rear of the valve is secure.

Temporarily fit the burner unit and ensure a suitable gas route can be achieved. Purge the gas supply thoroughly to remove air and dirt/debris before connection. Disconnect the inlet restrictor elbow from the inlet pipe.

Connect the previously installed gas supply to inlet restrictor elbow. Place the burner unit into the firebox making sure that the rear lugs locate properly on to the ledge in the firebox. Fit the two securing screws through the burner legs to secure the assembly. Re-fit the restrictor elbow to the inlet pipe of the appliance.

11.3 FUEL BED LAYOUT

Please see the relevant section of the user instructions.

11.4 FITTING THE FIREFRONT/FRAME

All models : Remove all protective film and packaging material before fitting.

One piece frame models : The appliance is supplied with a one piece decorative frame that is attached to the front of the firebox with the magnets provided. Position the firefront in front of the burner.

Three piece frame models : The clip-on frame pieces should be hooked over the outer edges of the fireframe, (figure 14), and pushed firmly home. The sides should be fixed first, followed by the top bar, which overlaps the sides. Push firmly home.

IMPORTANT : Due to the possibility of sharp edges, care should be taken when handling the three-piece frame components. The use of protective gloves is strongly recommended.

Casona models : Remove the decorative frame from its protective packaging. The frame is supplied with pre attached magnets. Simply place the frame onto the front of the firebox. The control cover is retained onto the frame with two hooks.

Cast frame models : Remove the decorative frame from its protective packaging. The frame is retained onto the firebox with a mounting bracket at the top of the frame and three magnets on each leg of the frame.

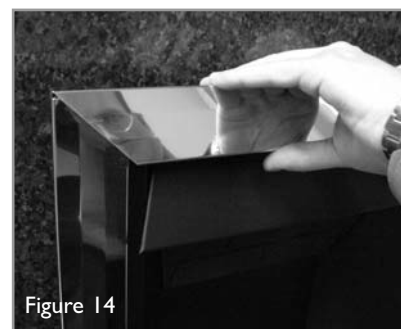

Figure 14

12.0 TESTING AND COMMISSIONING

Turn on and test the gas supply up to the fire for any leaks, in accordance with current edition of BS6891.

When the appliance is first used, protective oils coating the firebox may burn off. It is advisable to ventilate the room during this period for at least one hour.

12.1 OPERATING THE FIRE - MANUAL CONTROL MODELS

GB IE

The pilot is visible through the left hand side of ceramic fuel matrix. When cold, the coals or pebbles may be rotated for good viewing. The fire features a 'twin spark' ignition system to aid lighting. Push the control knob in fully and turn anti-clockwise through both of the SPARK positions, keeping fully depressed, hold there for a few seconds. If the fire has not been used for some time, hold the knob in this position for longer, to allow any air in the pipes to be purged.

Continue turning anti-clockwise through the spark clicks to the nine o'clock position, ensuring the pilot has lit. If not, return the knob clockwise, and repeat.

When the pilot lights after one of the two sparks, keep the knob depressed in the nine o'clock position for approximately ten seconds. Now release the knob and the pilot should stay alight. If the pilot is extinguished during use, wait three minutes before repeating the ignition procedure.

To achieve the HIGH setting, push the control knob in slightly and continue turning anti-clockwise to the high position. The main burner should light after a few seconds. To decrease the setting to LOW, push the knob in slightly and turn the control knob clockwise to the low setting. To turn to the pilot only position from the HIGH or LOW positions, press the control knob in, and return to the nine o'clock position and release. To turn the fire OFF, keep the knob pressed in, return to the off position and release.

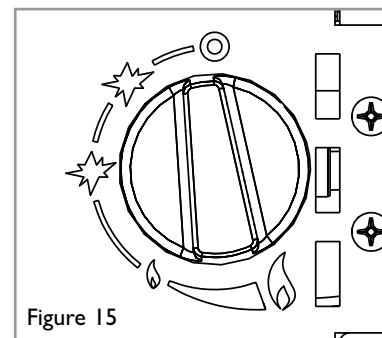

Figure 15

12.2 OPERATING THE FIRE - SLIDE CONTROL MODELS

The pilot is visible through the left hand side of the front ceramic strip. When cold, the coals or pebbles may be rotated for good viewing. Push the slide control knob fully downwards to the SPARK position, and hold there for a few seconds, until the pilot light stays on. When the pilot light has established, release the slide control knob and it will return to the LOW flame setting. If the pilot is extinguished during use, wait three minutes before repeating the ignition procedure.

To achieve the HIGH setting, move the slide control knob upwards to the HIGH flame setting. The fire can also be set to operate anywhere between HIGH and LOW by moving the control knob to an intermediate position.

To turn the fire OFF, move the slide control knob upwards fully to the position marked 'O'.

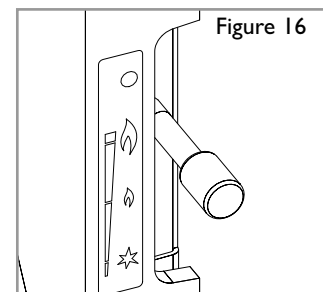

Figure 16

12.3 OPERATING THE FIRE - REMOTE CONTROL MODELS

The pilot is visible through the left hand side of the front ceramic strip. When cold, the coals or pebbles may be rotated for good viewing. Turn the main burner control (shown on left hand side of control valve) knob fully anti-clockwise.

Turn ignition knob (shown on right hand side of control valve) slightly left towards the ignition position until reaching the stop, press down and hold for 5 seconds (only pilot gas is flowing)

Continue pressing down the knob while turning further to the left to activate the piezo spark, continue to hold the knob down for a further 10 seconds after the pilot has been lit. If the pilot does not light repeat the previous steps.

Upon lighting and after the further 10 seconds, release the knob and turn further to the left to the ON position. The main burner will light and be controlled in accordance with the main burner control knob setting. Adjust the main burner control knob to the desired setting.

If the pilot is extinguished during use of the fire, you MUST wait ten minutes before repeating the ignition procedure.

To turn the main burner OFF whilst keeping the pilot flame lit, turn the ignition control knob to the pilot position then only the pilot will remain lit.

To shut the fire off completely, press the ignition control knob down and continue turning to the right from the pilot position to the OFF position.

A safety interlock prevents re-ignition of the pilot flame until the thermocouple has cooled sufficiently to allow the magnetic valve unit to reset itself.

The remote control unit allows operation of the main burner setting between maximum and pilot only setting. It does not permanently turn the pilot on or off.

The remote control handset incorporates an inbuilt safety feature to prevent the main burner being activated or turned up accidentally. It is necessary to press buttons 1 and 2 (see figure 18) simultaneously to turn the fire up.

To turn the fire down press button 3 only.

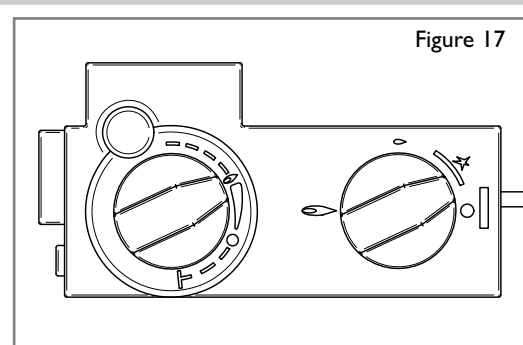

Figure 17

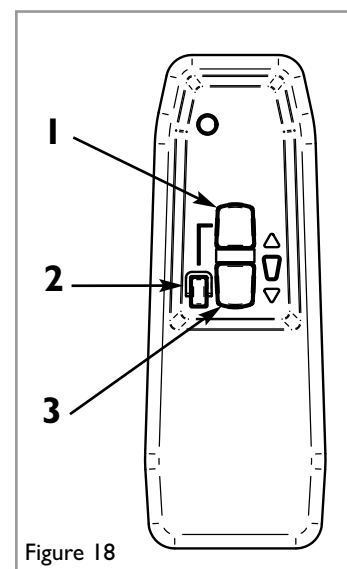

Figure 18

12.4 SPARK GAP

GB IE

The spark gap (shown in figure 19) between the spark electrode and the thermocouple should be 3.5 - 4.5mm to produce a good spark.

There should be no need to adjust this.

If under any circumstances the electric spark fails, the pilot may be lit manually by proceeding with the ignition sequence as previously described, and after turning the control knob through the spark position, the knob should be held in and the pilot lit with a taper.

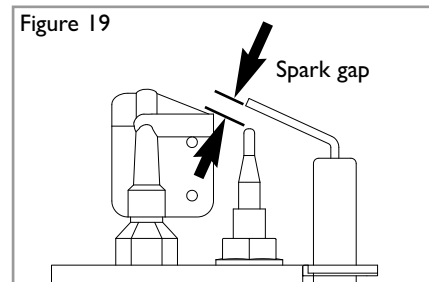

12.5 OPERATING PRESSURE - MANUAL MODELS

Release the pressure test point screw, and attach a pressure gauge. Light the fire on the HIGH setting. To commission the appliance, the operating pressure must be in accordance with the figures stated in section 2.0 of these instructions. The fire is factory set to achieve the correct flow rates at the specified inlet pressure.

Any significant variation in the inlet pressure could indicate a supply problem. If the inlet pressure is too high, the gas supply meter/governor may be set incorrectly. This should be checked with the fire running and if necessary reset by the gas supplier. If the inlet pressure is too low, then check the meter/governor pressure with the appliance running. If this is less than the inlet pressure stated in section 2.0 of these instructions it will need to be reset by the gas supplier. If the inlet pressure is too low, but the meter/governor pressure is acceptable, then a problem in the supply pipework is to be suspected. Upon satisfactory checking of the inlet pressure, turn the fire off, disconnect the pressure gauge and refit the test point screw. Light the fire and check for gas soundness. In the event that the inlet pressure is not in accordance with the figures stated in the data section of these instructions, the appliance must not be commissioned, and the problem investigated and rectified.

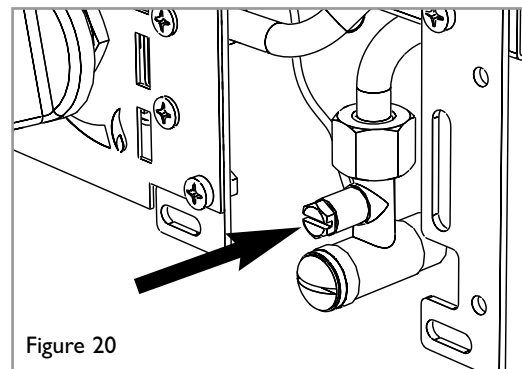

12.6 OPERATING PRESSURE - SLIDE & REMOTE CONTROL MODELS

Slide control models : The pressure test point is located directly above the gas valve in the centre of the burner.

Remote control models : The pressure test point is located on the right hand side of the burner, between the burner legs.

Release the pressure test point screw, and attach a pressure gauge. Light the fire on the HIGH setting. To commission the appliance, the burner pressure must be in accordance with the figures stated in section 2.0 of these instructions.

The fire is factory set to achieve these pressures and any significant variation could indicate a supply problem. If the pressure is too high, the gas supply meter may be set incorrectly. This should be checked with the fire running and if necessary reset by the gas supplier.

Upon satisfactory checking of the burner pressure, turn the fire off, disconnect the pressure gauge and refit the test point screw. Light the fire and check for gas soundness. In the event that the burner pressure is not in accordance with the figures stated in the data section of these instructions, the appliance must not be commissioned, and the manufacturer should be contacted for guidance.

12.7 FLUE SPILLAGE MONITORING SYSTEM

This fire is fitted with a flue spillage safety device (ODS). If the fire shuts down during use for no apparent reason then several things may be suspected. If a door or window has been opened creating a draught, then pilot disturbance is the problem, and removal of the draught should resolve this. The gas pressure reaching the fire must also be checked (again, recall your installer to check and rectify any problem). The thermocouple connection into the back of the gas control valve may also have worked loose during installation, simply get the installer to tighten. If pilot disturbance is not the cause, then the ODS safety system may be in operation. Switch the appliance OFF, check the flue and carry out any remedial work required. Relight the fire and carry out a spillage test.

DO NOT allow the appliance to be used if it continues to fail a spillage test. The aeration hole of the pilot must be carefully cleaned out on each annual service to ensure continued function of the ODS. The spillage monitoring system shall not be adjusted, modified, or put out of operation by the installer. Any spare parts fitted MUST be of a type supplied for the purpose by the appliance manufacturer. If the fire is not spilling, then further guidance should be sought, using the Troubleshooting section as a guide.

12.8 TESTING FOR SPILLAGE

Close all doors and windows to the room containing the appliance. Let the fire run on HIGH for five minutes. Take a smoke match, light it, and using a smoke match tube, hold it at the top edge of the fire opening, 25mm down and 25mm in. Starting 50mm in from either side, run the smoke match across the opening.

All the smoke should be drawn away up the flue. Any smoke returning into the room indicates that spillage is occurring. If the initial spillage test fails, run the fire for a further 10 minutes and repeat the test.

When the test has been completed satisfactorily, repeat with any extractor fans in the premises running on the highest setting, and any communicating doors open. Finally, repeat with all doors open.

Figure 21 : Cross section of smoke match tube

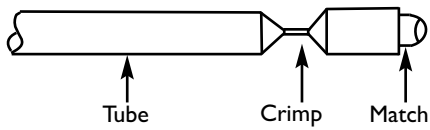

Make a smoke match tube from 10mm diameter tube. Seal off one end and crimp the tube to prevent the smoke match from sliding down inside.

Spillage test - Figure 22

- A. 25mm down from top of opening
- B. 25mm in from front of opening.
- C. Disregard outer 50mm either side of fireplace opening

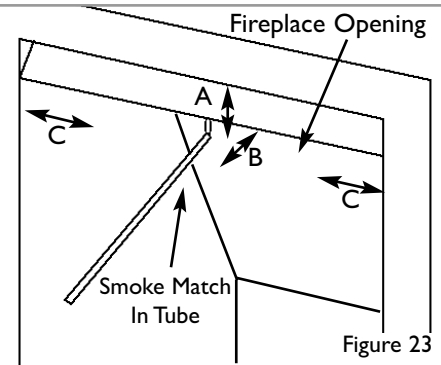

DO NOT allow the fire to be used until the test is satisfactorily passed.

12.9 BRIEFING THE CUSTOMER

All instructions must be handed to the user for safekeeping. Show the customer how to light and control the fire. After commissioning the appliance, the customer should be instructed on the safe use of the appliance and the need for regular servicing. Frequency of service depends on usage, but **MUST** be carried out at least once annually. Advise that cleaning of the fire may be achieved when the fire is cold using a damp cloth and mild detergent on most surfaces.

Scratched and other superficial damage to the matt black paintwork of the appliance can be covered with matching heatproof spray. Use only the manufacturers' recommended spray paint. Paint only when the fire is **OFF** and cold. Always mask off the surrounding area to prevent contamination with overspray. Ventilate the room during the use of the spray. **DO NOT** attempt to spray paint the coals or ceramics, or wash them in water.

Advise that the fire will emit a "newness" smell for a time after initial commissioning and that extra ventilation may be needed during this time. Advise that the fire is fitted with a spillage safety device (O.D.S.). If the fire shuts down, this system may be in operation. If spillage is suspected, **SWITCH APPLIANCE OFF** and call in the installer to investigate any problems.

13.0 SERVICING

Isolate the fire from the gas supply. Ensure that the fire is fully cold before attempting service. A suggested procedure for servicing is detailed below.

1. Lay out the dust sheet and tools.
2. Carefully remove the ceramic components.
3. Remove the cast front fret or the combined frame and firefront (dependant on model).
4. Disconnect the gas supply, and remove the two securing screws in the tray legs.
5. Remove the burner tray.
6. Remove firebox as described.
7. Check the fireplace opening for rubble accumulation and remove. If debris is excessive, initiate remedial work on the flue.
8. Check the flue with smoke pellet for correct operation.
9. Refit firebox using new seals where necessary.
10. Strip off the burner pipes and clean thoroughly.
11. Clean out the injector, pilot assembly and burner tube. **DO NOT** attempt to remove the pilot injector.
12. Re-assemble and re-fit the burner tray.
13. Turn on the gas supply, and leak test.
14. Refit the decorative firefront and ceramics.
15. Check any purpose provided ventilation is un-obstructed.
16. Light the fire and test for spillage.
17. Check operating pressure and safe operation of the appliance.

For specific servicing instructions, see the relevant sections.

13.1 CLEANING THE CERAMICS

Remove the firefront and place to one side. Remove the ceramic components. Gently clean in the open air. Be careful not to create dust from the coals. Where necessary replace damaged components with genuine spares. Seal scrap ceramic components in plastic bags and dispose at proper refuse sites as directed.

Re-fit the ceramics by referring to the relevant section of these instructions.

13.2 REMOVING THE BURNER

GB IE

Remove the decorative front. Remove the ceramics and place safely aside.

Slide control models - disconnect the slide control mechanism by removing the M4 nut on the slide control linkage.

Remove the two screws securing the tray legs to the firebox. Pull tray forward slightly and lift away.

Refitting is the reverse of above, being sure to engage the tray location lugs on the shelf at the rear of the firebox.

13.3 SERVICING THE BURNER

Remove the burner unit as previously described. The pilot unit can be removed by withdrawing the tubing nut, the thermocouple nut on the rear of the valve, and the two securing screws, and lifting away. Remove the tubing nut from the valve end of the pilot pipe, and blow through to dislodge any debris.

Remove the two tubing nuts on the ends of the gas pipe to the injector elbow and blow clear. Release the screw through the supporting leg and lift assembly clear. The injector pipe can now be checked for debris. Remove the nut retaining the injector elbow. Blow through the elbow to remove any debris.

13.4 PILOT ASSEMBLY

Remove the burner unit as in relevant section and pilot unit as described.

Clean the pilot assembly with a soft brush and blow through. Check the aeration holes are free of any dirt or lint. Clean thoroughly internally, the connection can be removed from the base of the pilot unit using two spanners to make cleaning easier. Do not damage or try to remove the pilot injector. The unit is factory set and the only check necessary is to ensure the spark gap is correct. See specifications for gap setting.

13.5 REMOVING THE FIREBOX

Remove the burner unit as described previously.

Protect the hearth from potential damage. Unroll the coiled tensioner cables from the rear of the firebox. Remove the securing nipples and tensioner adjusters. The firebox is now released from the opening and can be slid outward onto the hearth. Inspect the fire-place opening for debris and if excessive rectify the flue before proceeding further. Check the seal around the fireframe and if necessary replace. Refitting of the firebox is as described in the fitting section of these instructions.

13.6 REPLACING THE BATTERIES (SLIDE CONTROL VERSIONS)

Ensure appliance is off and cool. The battery is located in the top of the ignition unit, on the left hand side of the burner. Insert 1 x 'PP3' (9 volt) battery.

13.7 REPLACING THE BATTERIES (REMOTE CONTROL VERSIONS)

Handset - Remove cover from rear of handset and insert 1 x 'PP3' (9 volt) battery - Replace cover

Appliance - **Ensure appliance is off and cool.** Remove cover from top of receiver box. The cover is protected by reflective foil, and located towards the right hand side, underneath the burner unit. Insert 4 x 'AA' (1.5 volt) batteries - Replace cover.

Fire sparks but pilot does not light

- No gas to fire, check isolators are open and gas supply is on.
- Pipework blockage, clean out.
- Air not fully purged, re purge supply or wait longer.
- Spark earthing to metalwork, reset gap correctly.
- Blocked pilot, clean out internally.

Pilot lights but then goes out

- Severe restriction in gas supply: clear obstruction.
- Faulty thermocouple, replace pilot unit.
- Blocked pilot, clean out.
- Blocked lint gauze, clean.
- Hold control knob in for longer.
- If the pilot will not stay lit there could be a problem with contamination of the gas supply, drafts, ventilation or the thermocouple needs replacement.

Modifications are dangerous and can have a serious unseen effect on safety.

NEVER MODIFY OR BEND THE THERMOCOUPLE TO MAKE THE PILOT STAY ALIGHT.

Fire does not spark at pilot

- HT lead detached, refit.
- Replace battery (Slide control models only).
- Check the spark gap (see section 12.4).
- Faulty piezo unit, replace.
- Debris shorting out electrode, clean.
- Spark shorting to metalwork under tray, check routing of HT lead under burner.

Fire runs for a time and then cuts off

- Loose or faulty thermocouple, rectify.
- Blocked pilot, clean out.
- Excessive drafts in the room.
- Excessive flue pull.
- Fire is too close the an air vent.
- Dirt or lint in pilot aeration hole or on the lint gauze, clean thoroughly.
- If the pilot will not stay lit there could be a problem with contamination of the gas supply, drafts, ventilation or the thermocouple needs replacement.

Modifications are dangerous and can have a serious unseen effect on safety.

NEVER MODIFY OR BEND THE THERMOCOUPLE TO MAKE THE PILOT STAY ALIGHT.

Pilot flame shrinks when fire is on high

- Poor gas flow to fire, check pressure with fire on high.
- If pressure is low, remove any restriction in pipework or valve.
- Check all isolators are adequately sized and fully open.
- Check meter pressure is adequate.
- Firebox grommet seal missing, rectify.
- If the pilot will not stay lit there could be a problem with contamination of the gas supply, drafts, ventilation or the thermocouple needs replacement.

Modifications are dangerous and can have a serious unseen effect on safety.

NEVER MODIFY OR BEND THE THERMOCOUPLE TO MAKE THE PILOT STAY ALIGHT.

Fire smells when first lit or in use

- Newness smell from brand new appliance.
- Spillage occurring. Carry out Spillage test and rectify any problems.
- Combustible materials used in incorrect positions.
- Firebox grommet seal missing, rectify.
- Other airborne contaminants such as dust, tobacco smoke, paint vapours.

Section	Contents	Page No.	Section	Contents	Page No.
1.0	Important Notes	1	6.1	Fuel Bed Layout - Pebble effect	4
2.0	Clearances to Combustibles	1	6.2	Fuel Bed Layout - Log effect	5
3.0	Ventilation	1	7.0	Servicing	6
4.0	Operating Instructions - Manual control	2	8.0	Cleaning	6
4.1	Operating Instructions - Slide control	2	9.0	Replacing the Batteries (Slide control versions)	6
4.2	Operating Instructions - Remote control	2	9.4	Replacing the Batteries (Remote control versions)	6
5.0	Flue Spillage Monitoring System	3	10.0	List of Replacement Parts	7
6.0	Fuel Bed Layout - Coal Effect	3	11.0	Installation Details	7
			12.0	Service History	7

1.0 IMPORTANT NOTES

- The installation and Servicing of this fire **MUST** only be carried out by a GAS SAFE registered person in accordance with local Codes and/or Regulations, Building Regulations and the manufacturer's instructions. Failure to comply with these could lead to prosecution and invalidate the appliance warranty. In the event of gas leakage from the appliance, the gas supply must be turned off at the nearest isolating valve. This appliance is only suitable for the gas type for which it is supplied.
- Keep a note of the installer's name and address, the original purchase receipt and the date of installation. Failure to produce this information may invalidate the warranty. The appliance should be serviced regularly to ensure continued safe operation. See the servicing section for further reference. Frequency of service will depend on use, but **MUST** be carried out at least once annually.
- Parts of this appliance become naturally hot during use. It is recommended that a suitable fireguard is used, especially where young children, pets, the elderly or infirm are concerned. The manufacturer of this appliance considers all surfaces as working surfaces with the exception of the control knob and control panel.
- It is recommended that a suitable fireguard conforming to BS 8423 is used, especially where young children, the elderly, or infirm are concerned.
- The appliance should be serviced regularly to ensure continued safe operation. Frequency of service will depend on use, but **MUST** be carried out at least once annually.
- Combustible items, such as flooring and furniture and soft wall coverings (such as blown vinyl or embossed paper), low temperature surrounds etc may discolour if fitted too close to the fire. See relevant section for further details on clearances to combustibles. No combustible materials or flooring should protrude onto the hearth.
- This appliance incorporates a combustion monitoring system (ODS).
- **DO NOT** burn any foreign material on this fire, the ceramic fuel effect components must be of the correct type and laid out in accordance with the relevant section of these instructions.
- Failure to do so could create a hazard or lead to sooting.
- Before the appliance is installed, the chimney should be swept. All flues should be checked by the installer to ensure there are no defects or obstructions that may prevent the flow of combustion products.
- This appliance is fitted with a flue blockage safety device which will shut down the fire if abnormal flue conditions occur. It is **NOT** a substitute for an independently mounted Carbon Monoxide detector.
- This fire is supplied with a particular style of firefront. Use of the firefront will ensure an adequate airflow under the firebed for the correct functioning of this appliance. Use **ONLY** the firefront supplied with the appliance. Use of any other firefront could be dangerous.
- Should any home improvements be carried out to the property after the fire is installed, such as installation of extractor fans for example, the fire should be re-checked by a competent person for safe operation.

2.0 CLEARANCES TO COMBUSTIBLES

A combustible shelf may be fixed to the wall above the fire, providing that it complies with the dimensions given below.

<i>Maximum depth of shelf</i>	<i>Minimum distance from finished hearth surface to underside of shelf</i>
100mm	745mm
150mm	845mm
203mm	895mm

A non-combustible shelf may be fitted to within 10mm of the top edge of the fireplace opening. Combustible materials, such as wood, may be fitted to within 100mm of either side of the fireplace opening, providing the forward projection does not exceed 100mm.

Any combustible side walls must be at least 500mm to the side of the radiant heat source. As with all heating appliances, any decorations, soft furnishings, and wall coverings (i.e. flock, blown vinyl and embossed paper) positioned too close to the appliance may discolour or scorch.

3.0 VENTILATION

No purpose provided ventilation is normally required for this appliance. The requirements of other appliances operating in the same space or room, and the results of a spillage test must be taken into consideration when assessing ventilation requirements, this will have been carried out by your registered installer.

For Republic of Ireland, ventilation may be required, see IS 813, ICP3, IS 327, and any other rules in force.

WARNING :Ventilation openings (where fitted) must never be blocked or restricted in any way.

4.0 OPERATING THE FIRE - MANUAL CONTROL MODELS

GB IE

The pilot is visible through the left hand side of ceramic fuel matrix. When cold, the coals or pebbles may be rotated for good viewing. The fire features a 'twin spark' ignition system to aid lighting. Push the control knob in fully and turn anti-clockwise through both of the SPARK positions, keeping fully depressed, hold there for a few seconds. If the fire has not been used for some time, hold the knob in this position for longer, to allow any air in the pipes to be purged.

Continue turning anti-clockwise through the spark clicks to the nine o'clock position, ensuring the pilot has lit. If not, return the knob clockwise, and repeat. When the pilot lights after one of the two sparks, keep the knob depressed in the nine o'clock position for approximately ten seconds. Now release the knob and the pilot should stay alight. If the pilot is extinguished during use, wait three minutes before repeating the ignition procedure.

To achieve the HIGH setting, push the control knob in slightly and continue turning anti-clockwise to the high position. The main burner should light after a few seconds. To decrease the setting to LOW, push the knob in slightly and turn the control knob clockwise to the low setting. To turn to the pilot only position from the HIGH or LOW positions, press the control knob in, and return to the nine o'clock position and release. To turn the fire OFF, keep the knob pressed in, return to the off position and release.

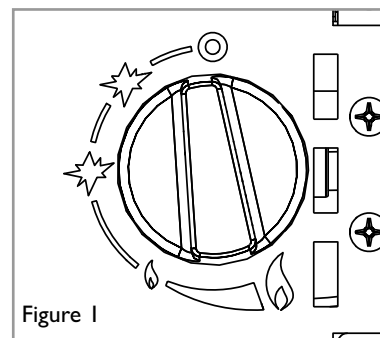

Figure 1

4.1 OPERATING THE FIRE - SLIDE CONTROL MODELS

The pilot is visible through the left hand side of the front ceramic strip. When cold, the coals or pebbles may be rotated for good viewing. Push the slide control knob fully downwards to the SPARK position, and hold there for a few seconds, until the pilot light stays on. When the pilot light has established, release the slide control knob and it will return to the LOW flame setting. If the pilot is extinguished during use, wait three minutes before repeating the ignition procedure.

To achieve the HIGH setting, move the slide control knob upwards to the HIGH flame setting. The fire can also be set to operate anywhere between HIGH and LOW by moving the control knob to an intermediate position.

To turn the fire OFF, move the slide control knob upwards upwards fully to the position marked 'O'.

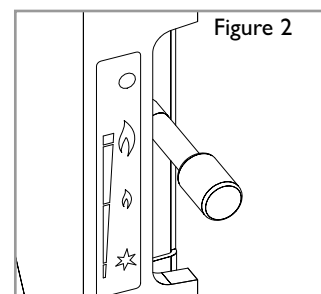

Figure 2

4.2 OPERATING THE FIRE - REMOTE CONTROL MODELS

The pilot is visible through the left hand side of the front ceramic strip. When cold, the coals or pebbles may be rotated for good viewing. Turn the main burner control (shown on left hand side of control valve) knob fully anti-clockwise.

Turn ignition knob (shown on right hand side of control valve) slightly left towards the ignition position until reaching the stop, press down and hold for 5 seconds (only pilot gas is flowing)

Continue pressing down the knob while turning further to the left to activate the piezo spark, continue to hold the knob down for a further 10 seconds after the pilot has been lit. If the pilot does not light repeat the previous steps.

Upon lighting and after the further 10 seconds, release the knob and turn further to the left to the ON position. The main burner will light and be controlled in accordance with the main burner control knob setting. Adjust the main burner control knob to the desired setting.

If the pilot is extinguished during use of the fire, you **MUST** wait ten minutes before repeating the ignition procedure.

To turn the main burner OFF whilst keeping the pilot flame lit, turn the ignition control knob to the pilot position then only the pilot will remain lit.

To shut the fire off completely, press the ignition control knob down and continue turning to the right from the pilot position to the OFF position.

A safety interlock prevents re-ignition of the pilot flame until the thermocouple has cooled sufficiently to allow the magnetic valve unit to reset itself.

The remote control unit allows operation of the main burner setting between maximum and pilot only setting. It does not permanently turn the pilot on or off.

The remote control handset incorporates an inbuilt safety feature to prevent the main burner being activated or turned up accidentally. It is necessary to press buttons 1 and 2 (see figure 4) simultaneously to turn the fire up.

To turn the fire down press button 3 only.

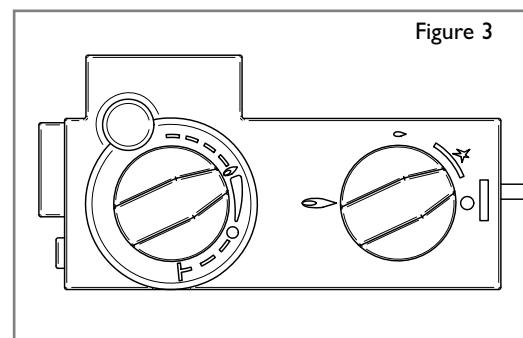

Figure 3

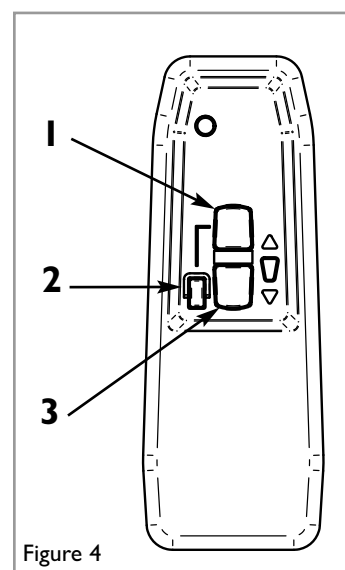

Figure 4

5.0 FLUE SPILLAGE MONITORING SYSTEM

GB IE

This fire is fitted with a flue spillage safety device (ODS). If the fire shuts down during use for no apparent reason then several reasons may be suspected. If a door or window has been opened creating a draught, then pilot disturbance could be the problem, and removal of the draught should resolve this. The fire can then be re-lit in accordance with the previous section. If pilot disturbance is not the cause, then the ODS safety system may be in operation. Switch the appliance OFF, call in your installer to check any ventilation and carry out any remedial work required. DO NOT allow the appliance to be used until the installation is passed as safe.

6.0 FUEL BED LAYOUT - COAL EFFECT

Coal effect models

1. Position the combustion matrix onto the burner tray as shown in figure 5. The front edge of the matrix should sit snugly behind the back edge of the burner rails as shown in figure 6. Do not fit the matrix on top of the burner rails.

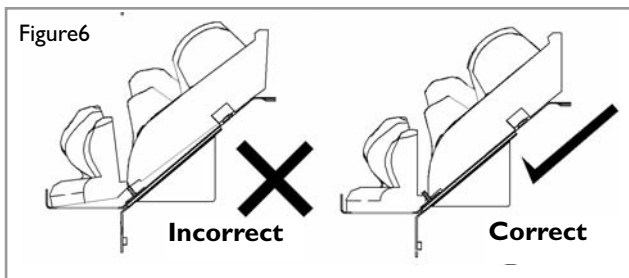

2. Position the front coal strip as shown in figure 7. The rear edge of the front coal strip should fit in front of the burner rail. Again, do not place on top of the burner rails.

When the front coal is in position bend up the three metal tabs at the front of the tray to retain as shown in figure 8.

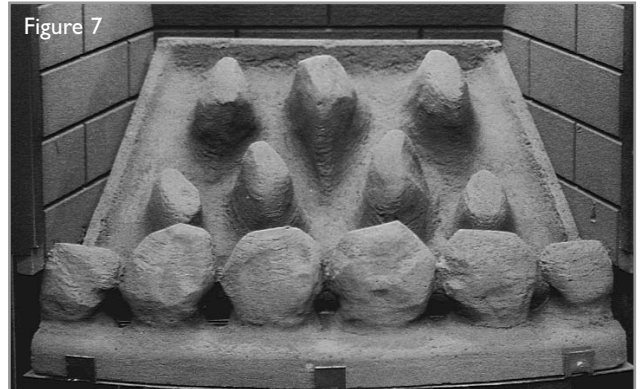
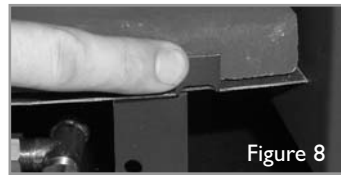

3. Coals. All of the coals are the same. Take five coals and place them as shown in figure 9. Care should be taken to ensure that the coals bridge the gap between the front coal and the four coal supports at the front of the matrix. Care should also be taken not to push the coals right down between the coal supports, as this can detract from the flame picture when the appliance is running.



4. Take five more moulded coals and position as shown in figure 10 to form the 'second row' of the fuel effect. The coals may be rotated as desired to fit into the gaps between the coal supports in order to create a random, realistic effect. Again, remember not to push the coals down too far into the valleys between the coal supports as this can have a detrimental effect to the flame picture.



5. Take another four coals and place behind the second row of coals as shown in figure 11, in order to complete the third row. The coals may be orientated as desired to achieve a realistic effect. Keep the spacing between the coals even and uniform. The two coals at the ends of the row may be placed rearwards, towards the back corners of the fuel matrix.



6. Finally, take the two remaining coals and place at the back of the fuel matrix, in the centre as shown in figure 12. Adding these coals should complete the appearance of the fuel bed giving an even distribution of equally spaced coals.



IMPORTANT : The fire is designed to operate correctly with the coals supplied when assembled according to the instructions. Never add to the sixteen coals, or change them for a different type. Never throw rubbish or other matter onto the coal bed.

6.1 FUEL BED LAYOUT - PEBBLE EFFECT

1. Refer back to section 6.0 - Fuel bed layout - coal effect and follow steps 1 and 2. The front strip and fuel effect matrix used for pebble effect versions are of the same design as coal effect versions, but have a different surface finish. Position them as shown in figure 13.

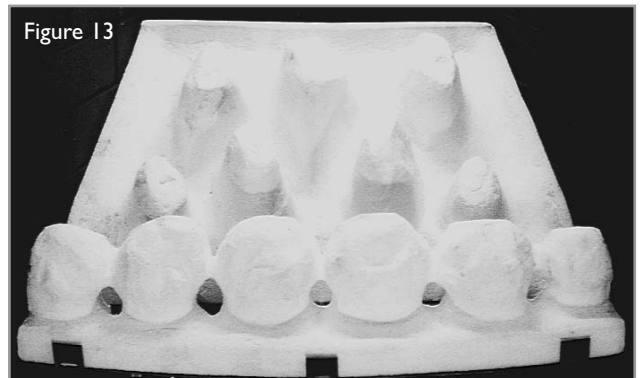

2. Open the bag of 16 ceramic pebbles. All of these pebbles are the same size. Take five pebbles and place them as shown in figure 14. Care should be taken to ensure that the pebbles bridge the gap between the front strip and the four supports at the front of the matrix. Care should also be taken not to push the pebbles right down between the supports, as this can affect the flame picture when the appliance is running.

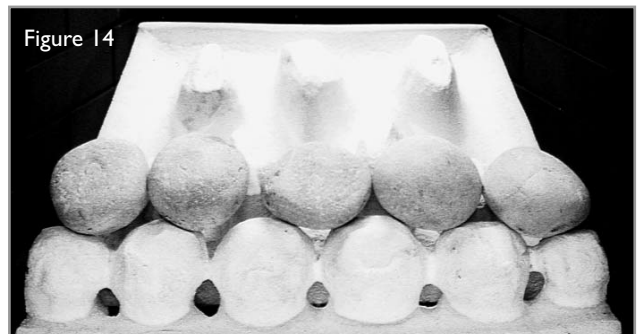

3. Take five more ceramic pebbles and position as shown to form the 'second row' of the fuel effect as shown in figure 15. The pebbles may be rotated as desired to fit into the gaps between the supports in order to create a random, realistic effect. Again, remember not to push the pebbles down too far into the valleys between the supports as this can have a detrimental effect to the flame picture.



4. Now take another two pebbles and place behind the second row of pebbles next to each other in the centre of the fuel bed as shown in figure 16. The pebbles may be orientated as desired to achieve a realistic effect. Keep the spacing between the pebbles even and uniform.

Figure 16



5. Finally, take the four remaining pebbles and place at the back of the fuel matrix as shown in figure 17.

Once again, the pebbles may be orientated as desired in order to give a realistic effect. Avoid pushing the pebbles down between the supports. The fuel bed layout is now complete.

Figure 17



IMPORTANT : The fire is designed to operate correctly with the pebbles supplied when assembled according to the instructions. Never add to the sixteen pebbles, or change them for a different type. Never throw rubbish or other matter onto the fuel bed.

Due to the light colour of the pebbles, some discolouration/sooting is to be expected during normal use.

6.2 FUEL BED LAYOUT - LOG EFFECT

1. Refer back to section 6.0 - Fuel bed layout (coal effect option) and follow steps 1 and 2. The fuel effect matrix used for log effect versions is the same design as coal effect versions, but has a different surface finish. The front log strip is of a different design and must be handled with care. Position them as shown in figure 18.

Figure 18



2. Open the bag of 9 moulded ceramic logs. All of the logs except two are the same. Take the largest log (numbered 16) and place it as shown. Care should be taken to ensure that the orientation is correct and the log fits snugly into its position.

Figure 19



3. Take the two medium sized logs (numbered 15 and 8) position the log numbered 8 on the left hand side as shown in figure 20, ensuring correct orientation. Place the log numbered 15 on the right hand side as also shown in figure 19, again ensuring correct orientation. Both these logs will fit securely into their allocated position, they may require rotating slightly to ensure this.

Figure 20



4. Now take the remaining large log (numbered 4) and position vertically as shown in figure 21, ensuring correct orientation. The base of this log must rest securely on the front log strip. Take one of the smaller logs (numbered 14) and position in between the two vertically positioned logs ensuring the orientation is correct. Keep the spacing between these logs uniform.



5. Finally, take the remaining two medium sized logs (numbered 5 and 7) and place in a horizontal position shown, 5 first, resting on the front log strip. 7 next resting on 5. Now take the smallest log (numbered 12) and position in the orientation shown ensuring the log does not fall into the matrix but rests securely on the allocated supports. Now take the final log (numbered 14) and place in a horizontal position as shown. Ensure there is even spacing between the logs and rotate if necessary to provide a stable fit onto the matrix. The fuel bed layout is now complete.



IMPORTANT : The fire is designed to operate correctly with the logs supplied when assembled according to the instructions. Never add to the nine logs, or change them for a different type. Never throw rubbish or other matter onto the fuel bed.

7.0 SERVICING

The fire and flue should be checked on an annual basis to ensure all of the product of combustion are entering the flue and that there is no excessive build up of soot. The frequency of service will depend on usage, but **MUST** be carried out at least once annually. Servicing must be carried out by a GAS SAFE registered engineer.

Cleaning of the coals/pebbles may be carried out by following the instructions given in section 6.0 of these instructions. The Installation instructions carry full servicing details for the use of the installer.

If debris from the flue or other foreign matter is found on the fire it may indicate a need for servicing. Do not use the fire until the source of the debris has been found and rectified. Air vents (where fitted) should be checked periodically to ensure they are free from obstruction.

8.0 CLEANING

Before carrying out any of the following operations, ensure that the fire is OFF and completely cold.

FIREFRONT - Any dust accumulating in the firefront may be removed using a vacuum cleaner or dry cloth. Heavy stains may be removed by using a damp cloth and mild household detergent. Brass parts of the firefront may be cleaned using a suitable brass cleaner. Replace the front centrally against the fire after cleaning. Do not use a damp cloth to clean cast iron fronts (Edwardian and Victorian models) as this can cause the fronts to rust.

PAINTED AREAS - These can be cleaned using a dry cloth.

COALS AND CERAMICS - Remove the firefront and place to one side. Remove the ceramic components. Gently clean in the open air. Be careful not to create dust from the coals. Where necessary replace damaged components with genuine spares. Seal scrap components in plastic bags and dispose of at proper refuse sites as directed. Re-fit the ceramics carefully by referring to section 6.0 of these instructions.

9.0 REPLACING THE BATTERIES (SLIDE CONTROL VERSIONS)

Ensure appliance is off and cool. The battery is located underneath the ignition unit, on the left hand side of the burner. Insert 1 x 'PP3' (9 volt) battery.

9.1 REPLACING THE BATTERIES (REMOTE CONTROL VERSIONS)

Handset - Remove cover from rear of handset and insert 1 x 'PP3' (9 volt) battery - Replace cover

Appliance - **Ensure appliance is off and cool.** Remove cover from top of receiver box.

The cover is protected by reflective foil, and located towards the right hand side, underneath the burner unit. Insert 4 x 'AA' (1.5 volt) batteries - Replace cover.

